

# Evolution of Multilane Roundabouts in Georgia

## Adding Raised Lane Dividers to Improve Safety

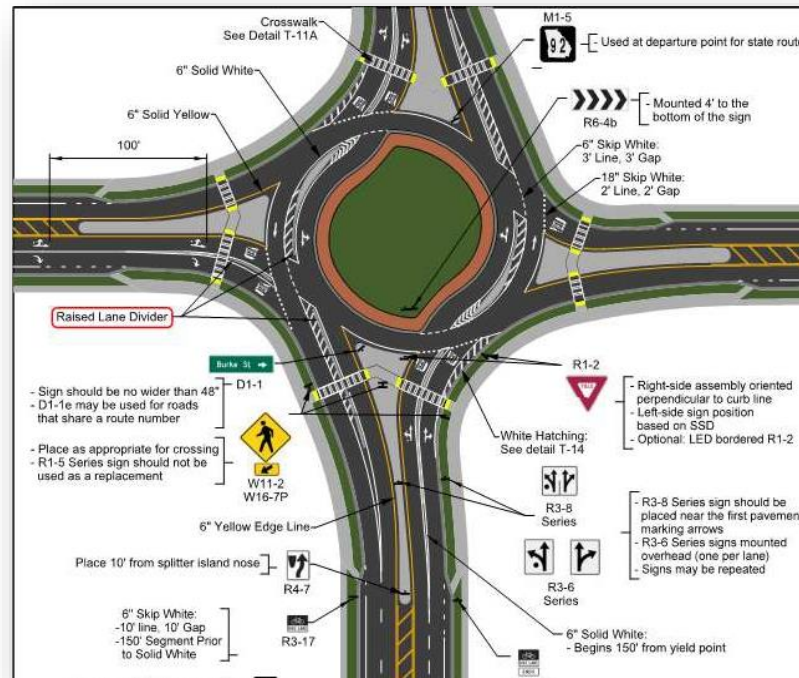

**GDOT**

**Oladimeji Onabanjo, PE**

**State Traffic Operations Manager**

**Arcadis**

**Jaap Tigelaar**

**Senior Transportation Engineer**

# Roundabouts in Georgia

First roundabout constructed in 1999

Georgia currently has ~400 roundabouts in operation:

- 50 multilaners
- 28 compacts
- 27 minis
- 98 on State Route and/or with state funds



SR 36 @ Keys Ferry Rd



**In Operation**  
**98**

(on-system or state funding)  
400 total



**Under Construction**  
**50**

(on-system)



**In Development**  
**240**

(on-system)

## Roundabouts in Georgia

~400 In Operation Statewide

~100 In Operation on State Routes

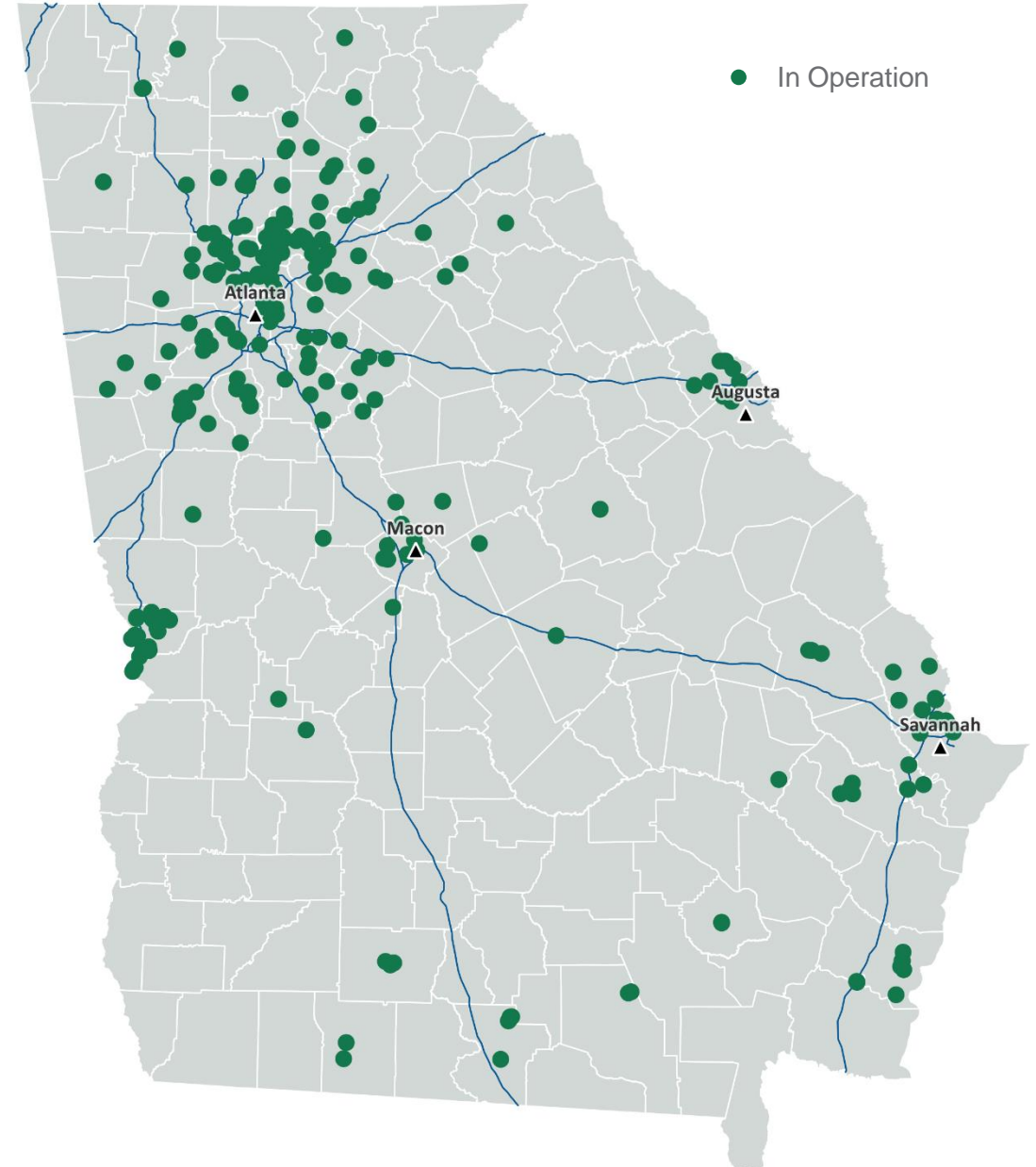

## Roundabouts in Georgia

~400 In Operation Statewide

~100 In Operation on State Routes

**30 Under Construction on State Routes**

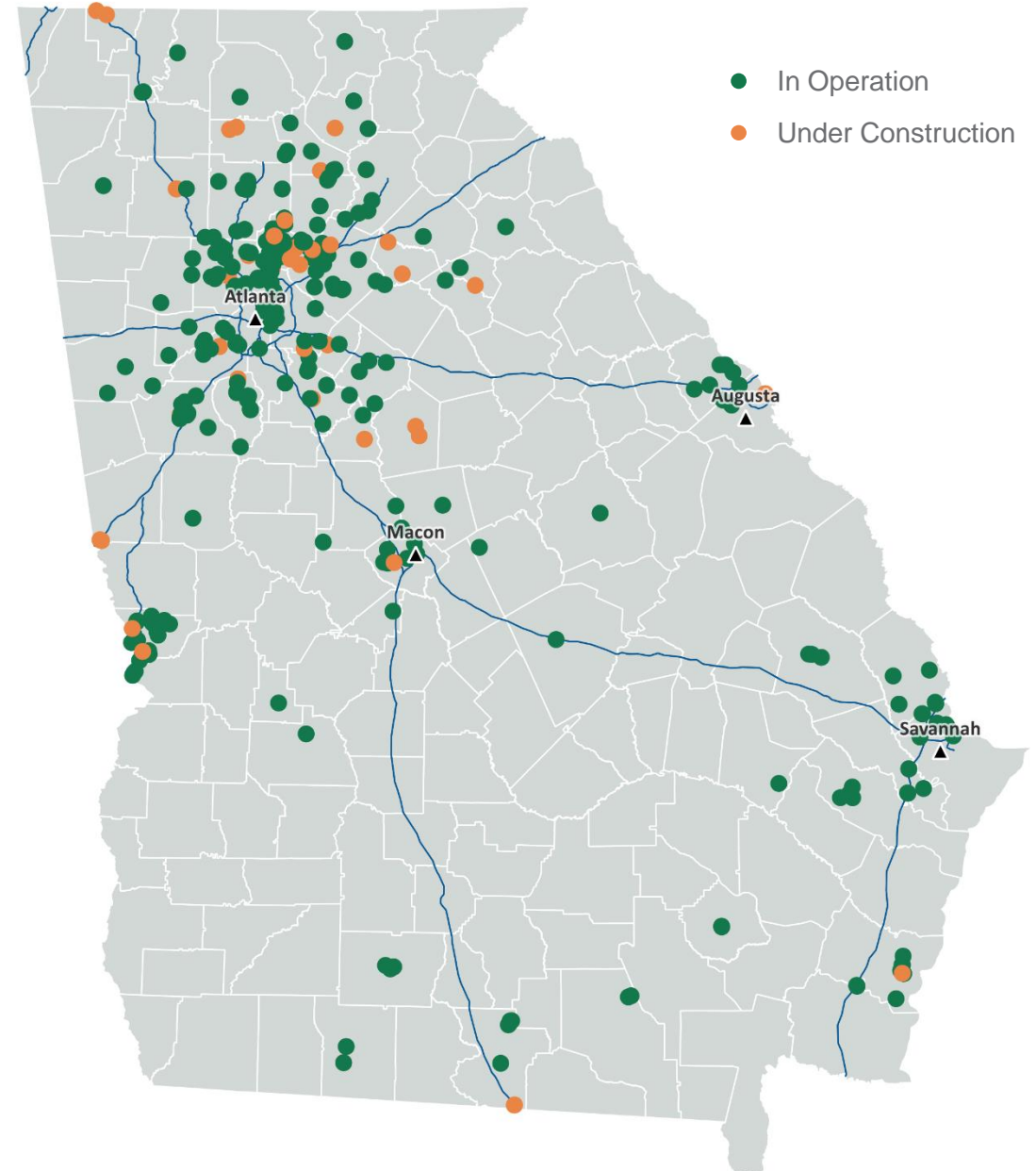

## Roundabouts in Georgia

~400 In Operation Statewide

~100 In Operation on State Routes

30 Under Construction on State Routes

170 Under Design on State Routes

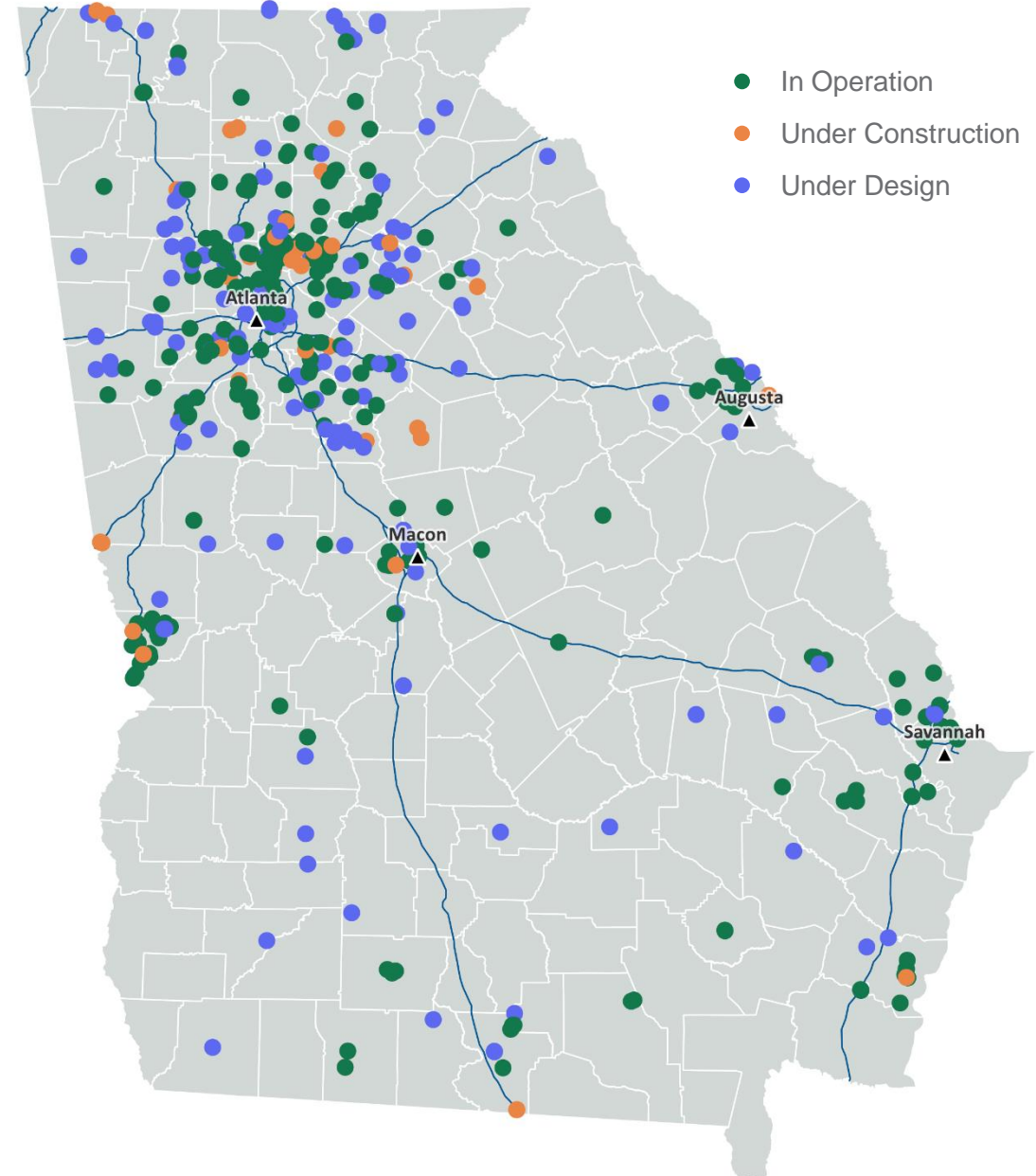

## Roundabouts in Georgia

~400 In Operation Statewide

~100 In Operation on State Routes

30 Under Construction on State Routes

170 Under Design on State Routes

30 Proposed on State Routes

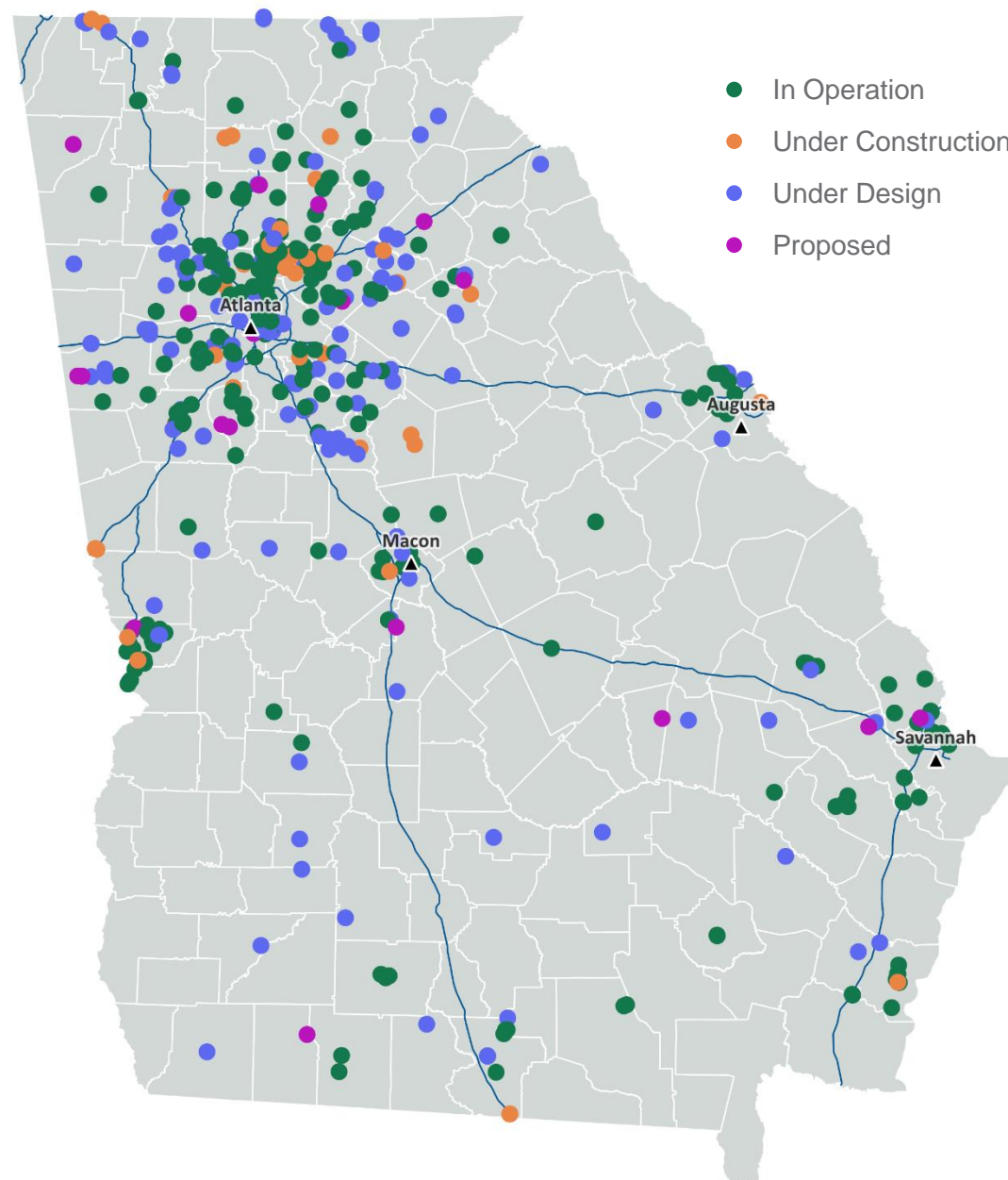

# Timeline of Multilane Roundabouts in Georgia

**Roundabout Policy  
Introduced**

Introduction of first policy in 2004

Only allowing single lane roundabouts

2004 | 2005 | 2006 | 2007 | 2008 | 2009 | 2010 | 2011 | 2012 | 2013 | 2014 | 2015 | 2016 | 2017 | 2018 | 2019 | 2020 | 2021 | 2022 | 2023 | 2024

# Timeline of Multilane Roundabouts in Georgia

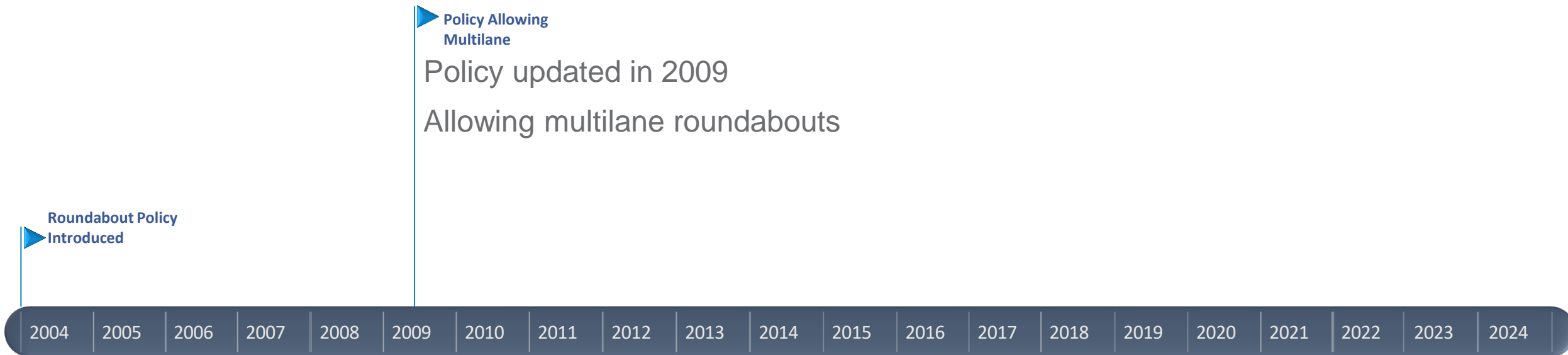

# Timeline of Multilane Roundabouts in Georgia

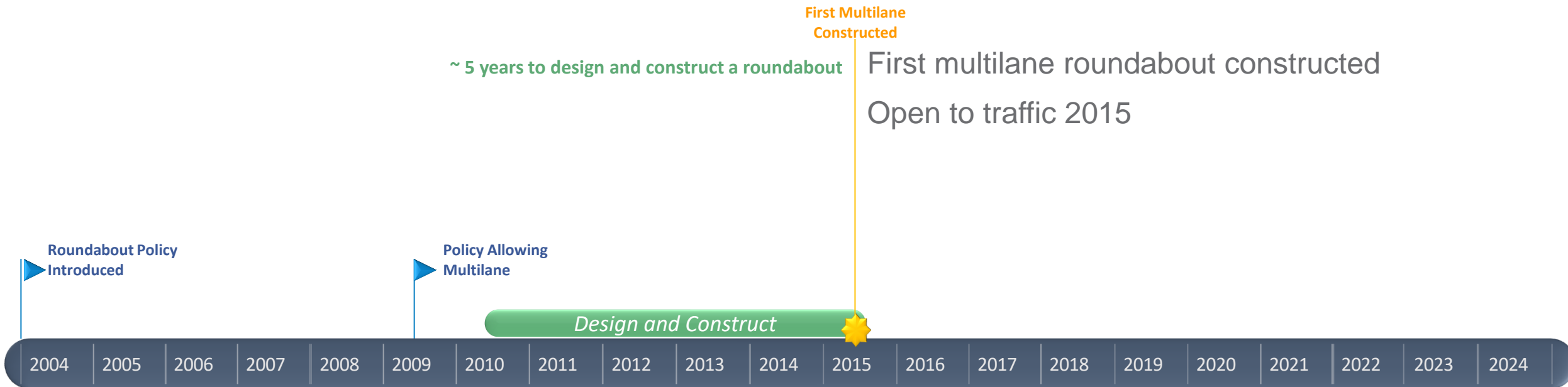

# Timeline of Multilane Roundabouts in Georgia

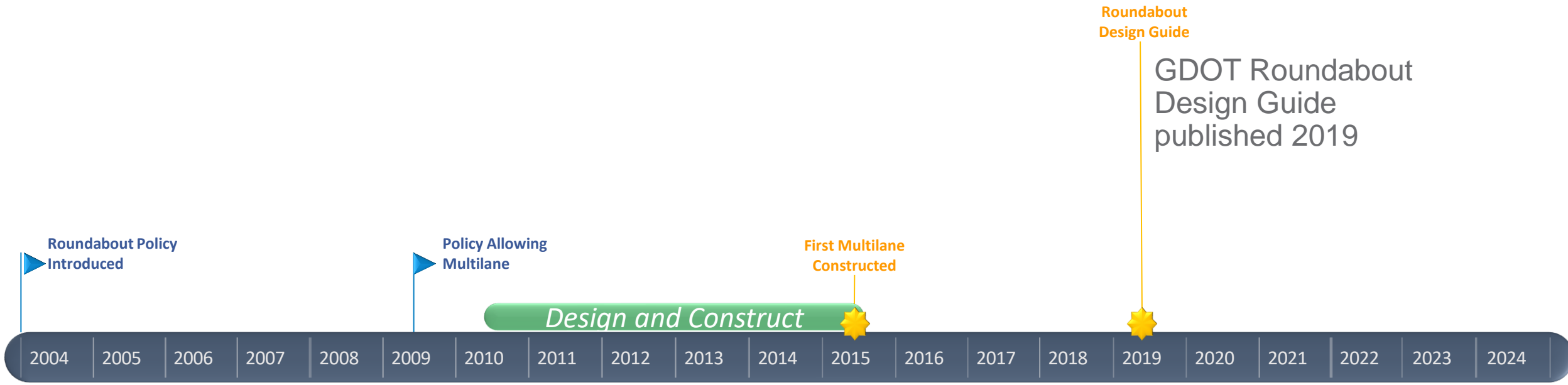

# Timeline of Multilane Roundabouts in Georgia

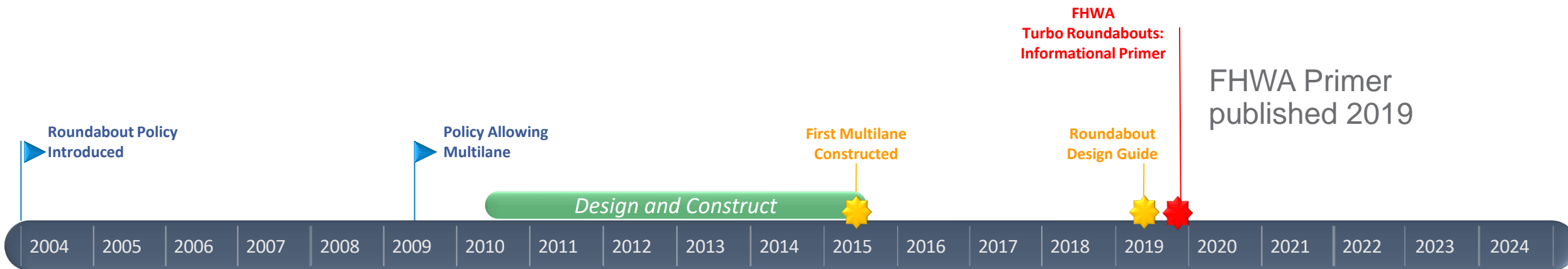

# Timeline of Multilane Roundabouts in Georgia

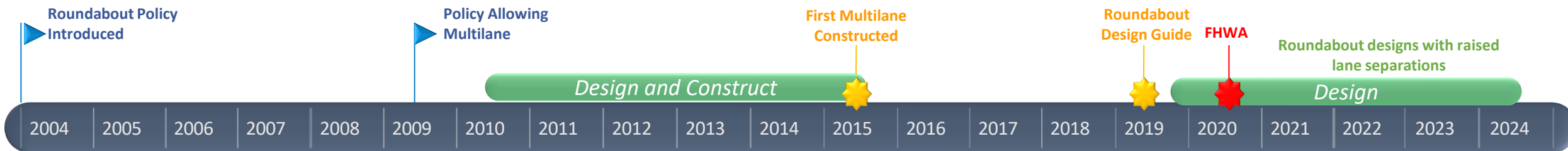

# Timeline of Multilane Roundabouts in Georgia

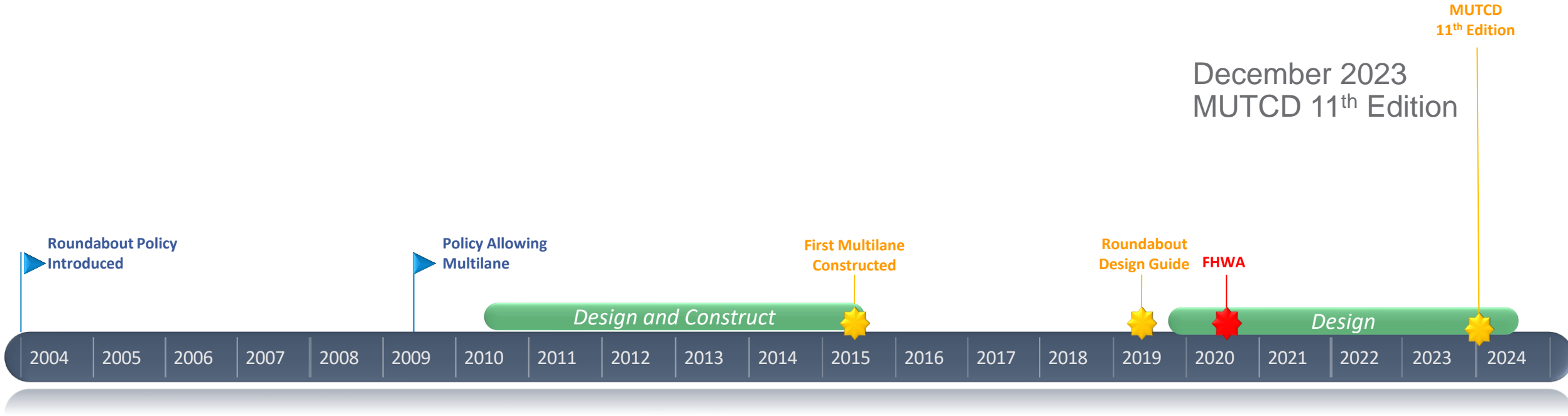

# Timeline of Multilane Roundabouts in Georgia

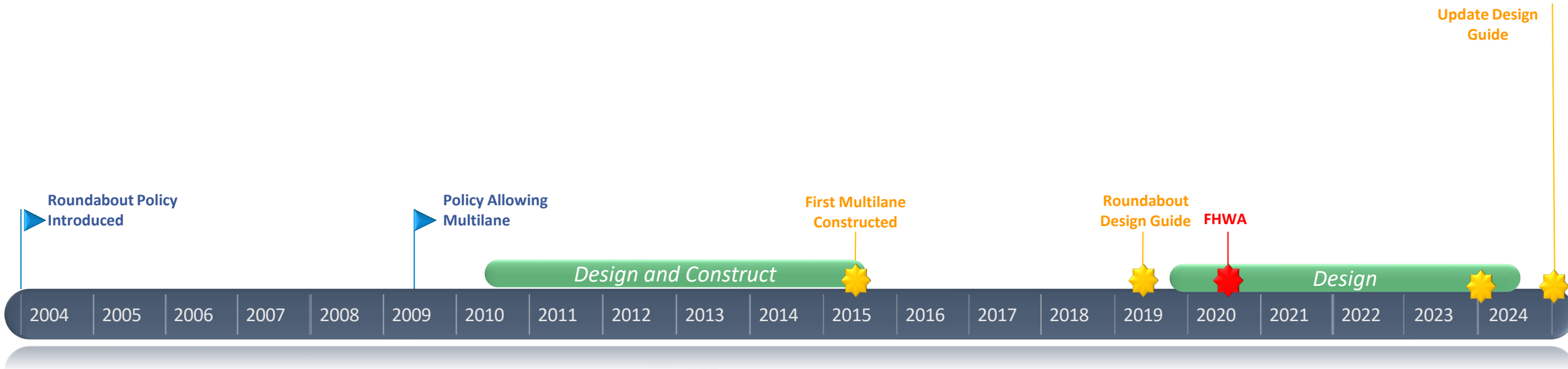

# Updated Roundabout Design Guide since 2019

## Roundabout Design Guide

- Expandable designs (2.1.1)
- **Added requirements and recommendations for multilane (3.15.2 Multilane Roundabout Cases)**
  - **Raised and flush elements**
  - **Spirals** (Appendix E)
- Active Devices (Metering, RRFB, PHB)
- Roundabout Railroad Crossing & Preemption (Ch 6)
- Landscaping Color & Texture Treatments (8.3)
- Roundabout performance checks
- Practical design
- High speed approach design
- To be continued....



11/15/2021  
Revision 2.0  
Atlanta, GA 30308

# Turbo Roundabout Characteristics

## Dutch Turbo Roundabout

- No Lane Changing
- Lane Change Upstream
- Spiral Layout
- Radial Approaches

Wanted to borrow the good elements



# Turbo Roundabout Characteristics

## GDOT Multilane Roundabout

- No Lane Changing
- Lane Change Upstream
- Spiral Layout
- Radial Approaches **Left Offset**
- Radius at the corner of the truck apron  
(Not hard corner used in the Dutch design)

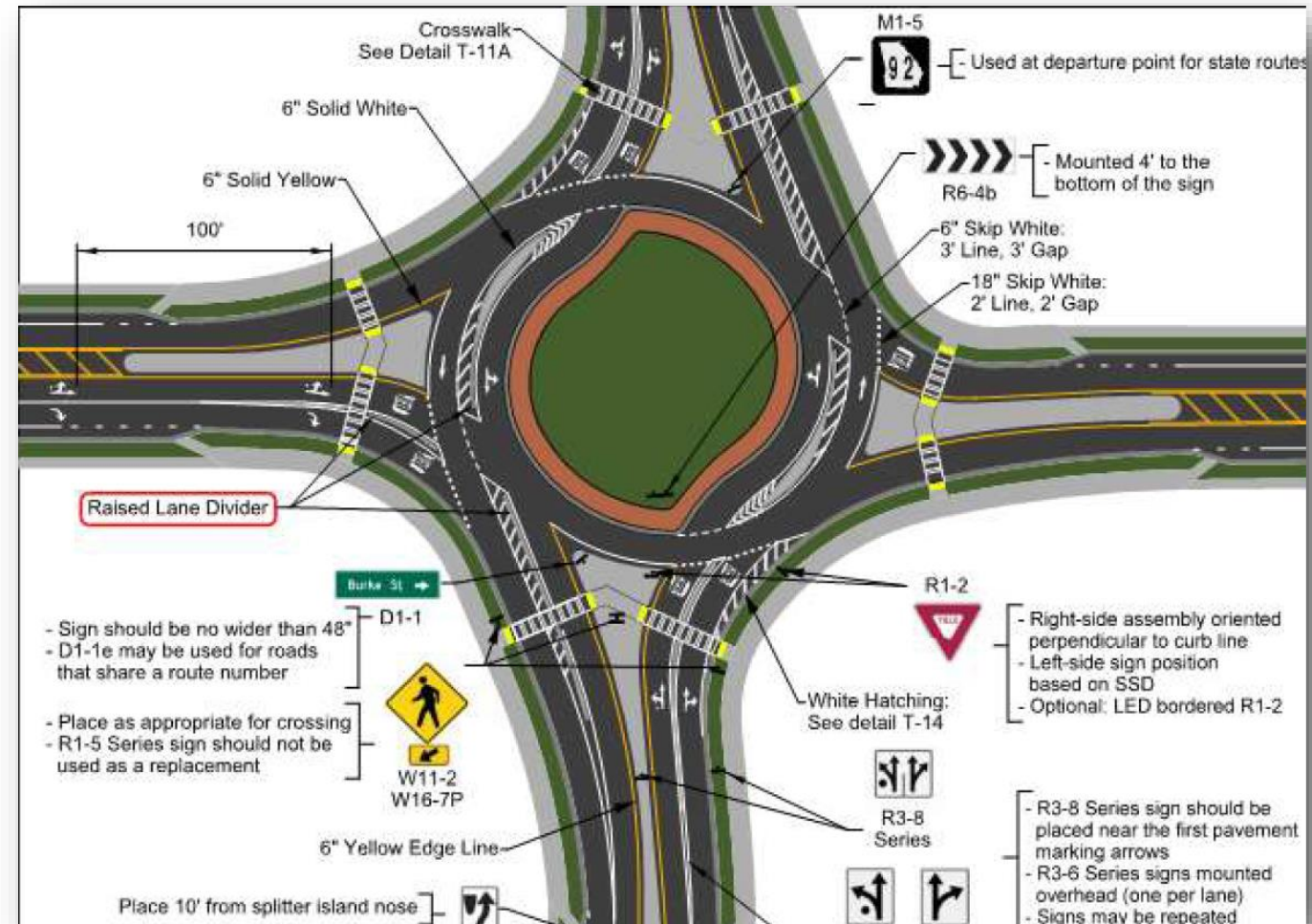

# Raised Lane Dividers – Lane Separation

## Benefits

- Positive Guidance
- Path Alignment
- Channelization
- Expected lower entry design speed
- Case 3: default design element for multilane roundabouts

Design Vehicle	Approach Lanes	Circulatory Lanes	Departure Lanes
<b>Case 1</b>	Over Track	Over Track	Over Track
<b>Case 2</b>	Stay in Lane	Over Track	Stay in Lane
<b>Case 3</b>	Stay in Lane	Stay in Lane	Stay in Lane

# Raised Lane Dividers – Lane Separation

## Benefits

- Positive Guidance
- Path Alignment
- Channelization
- Expected lower entry design speed

Design Vehicle	Approach Lanes	Circulatory Lanes	Departure Lanes
<b>Case 1</b>	<b>Flush Elements</b>	<b>Flush Elements</b>	<b>Flush Elements</b>
<b>Case 2</b>	Stay in Lane	<b>Flush Elements</b>	Stay in Lane
<b>Case 3</b>	Stay in Lane	Stay in Lane	Stay in Lane

# Raised Lane Dividers – Lane Separation

## Benefits

- Positive Guidance
- Path Alignment
- Channelization

Design Vehicle	Approach Lanes	Circulatory Lanes	Departure Lanes
Case 1	Flush Elements	Flush Elements	Flush Elements
Case 2	Raised Elements	Flush Elements	Raised Elements
Case 3	Raised Elements	Raised Elements	Raised Elements

# Lane Separation

## Raised Lane Dividers

- Type 1 or Type 9 Curb Face
- Height: 3"
- Flat surface for RPM
- White stripes on both sides
- Short gaps optional for drainage

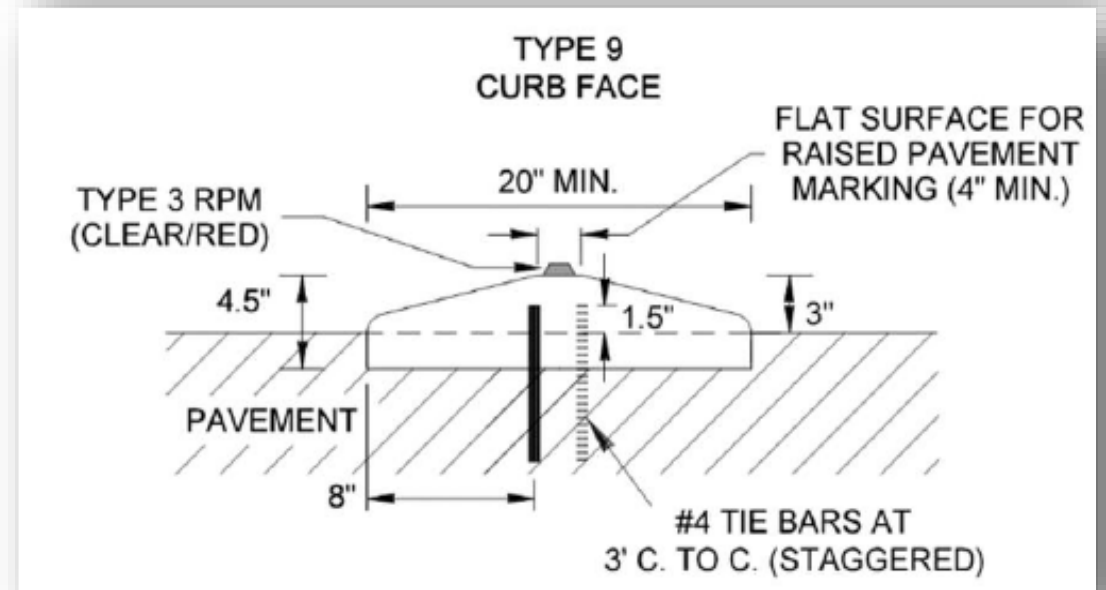
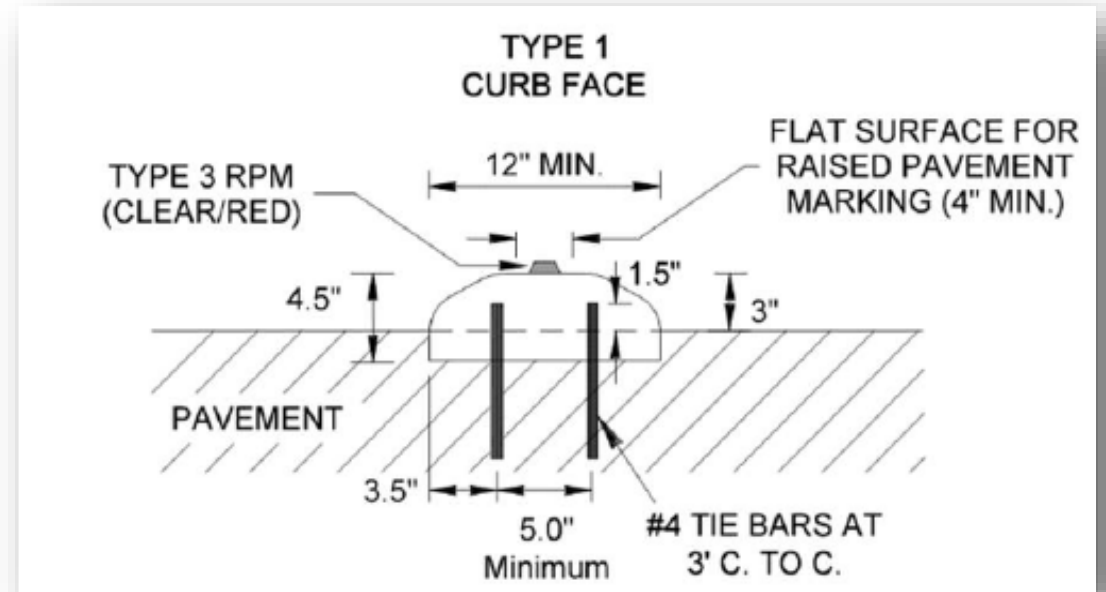

## Lane Separation

### Raised Lane Dividers

Example of Case 3  
design

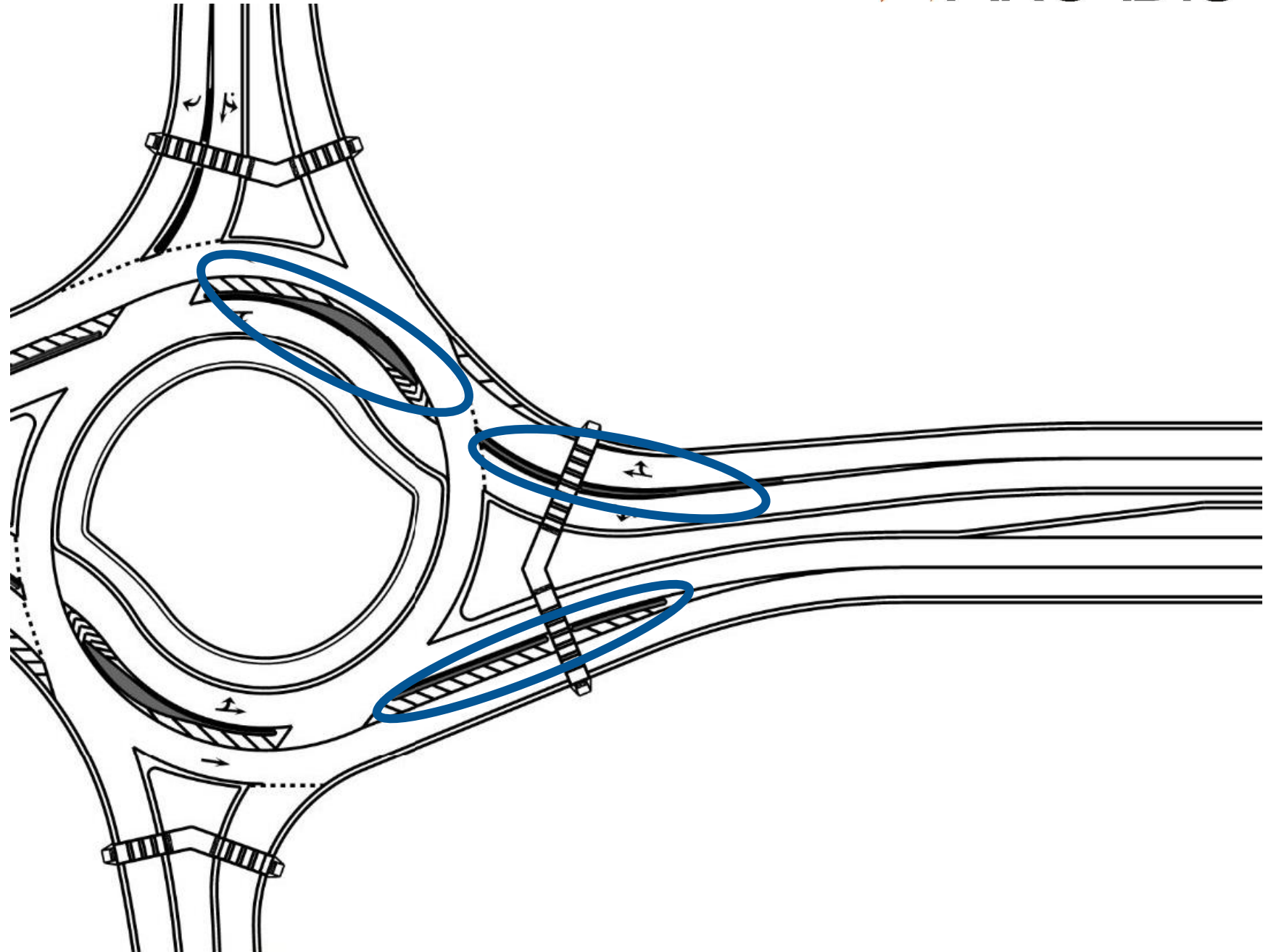

# Lane Separation

## Raised Lane Dividers – Tapered Nose (frog)

Transition the beginning of the raised divider

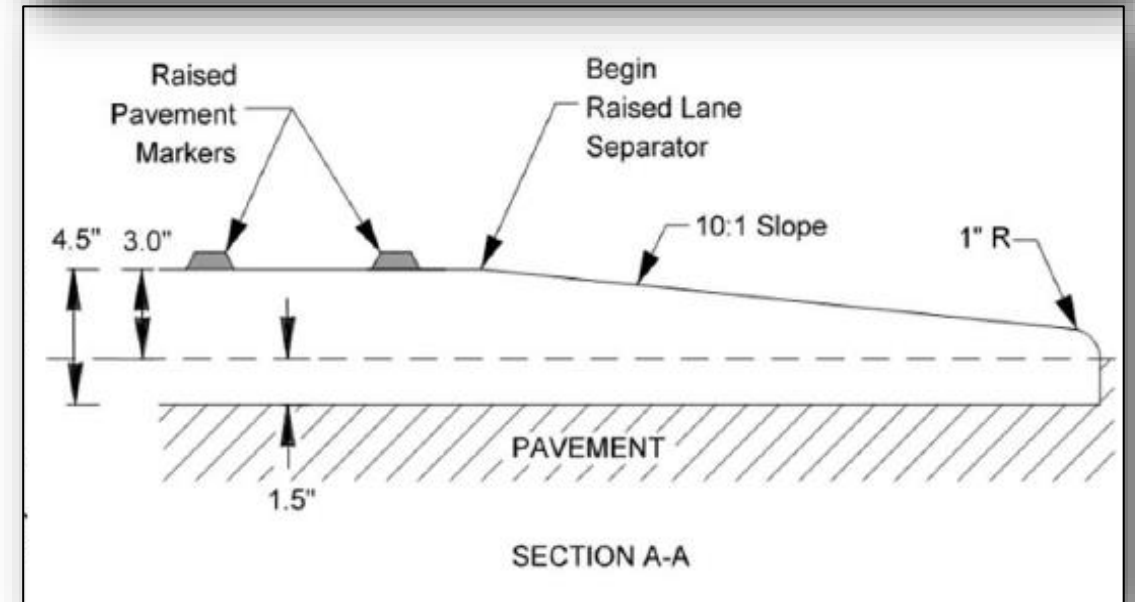
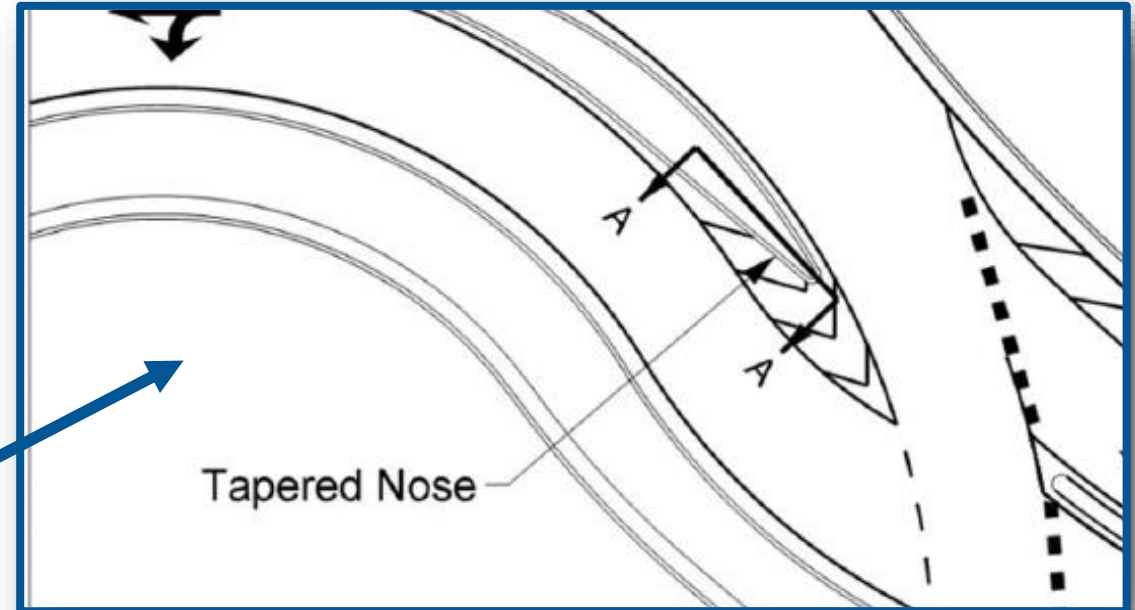
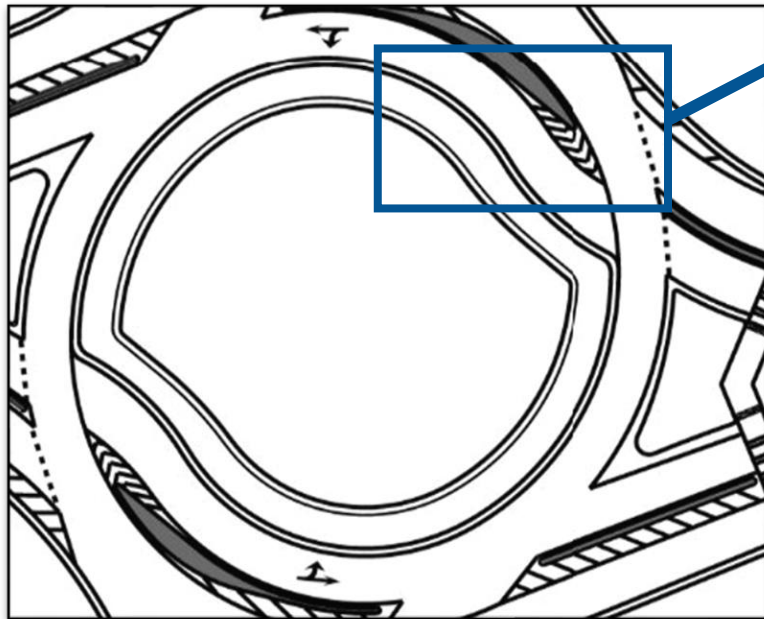

## Lane Separation

### Raised Lane Dividers – Tapered N

Critical to avoid path overlap

Opening width: keep it small

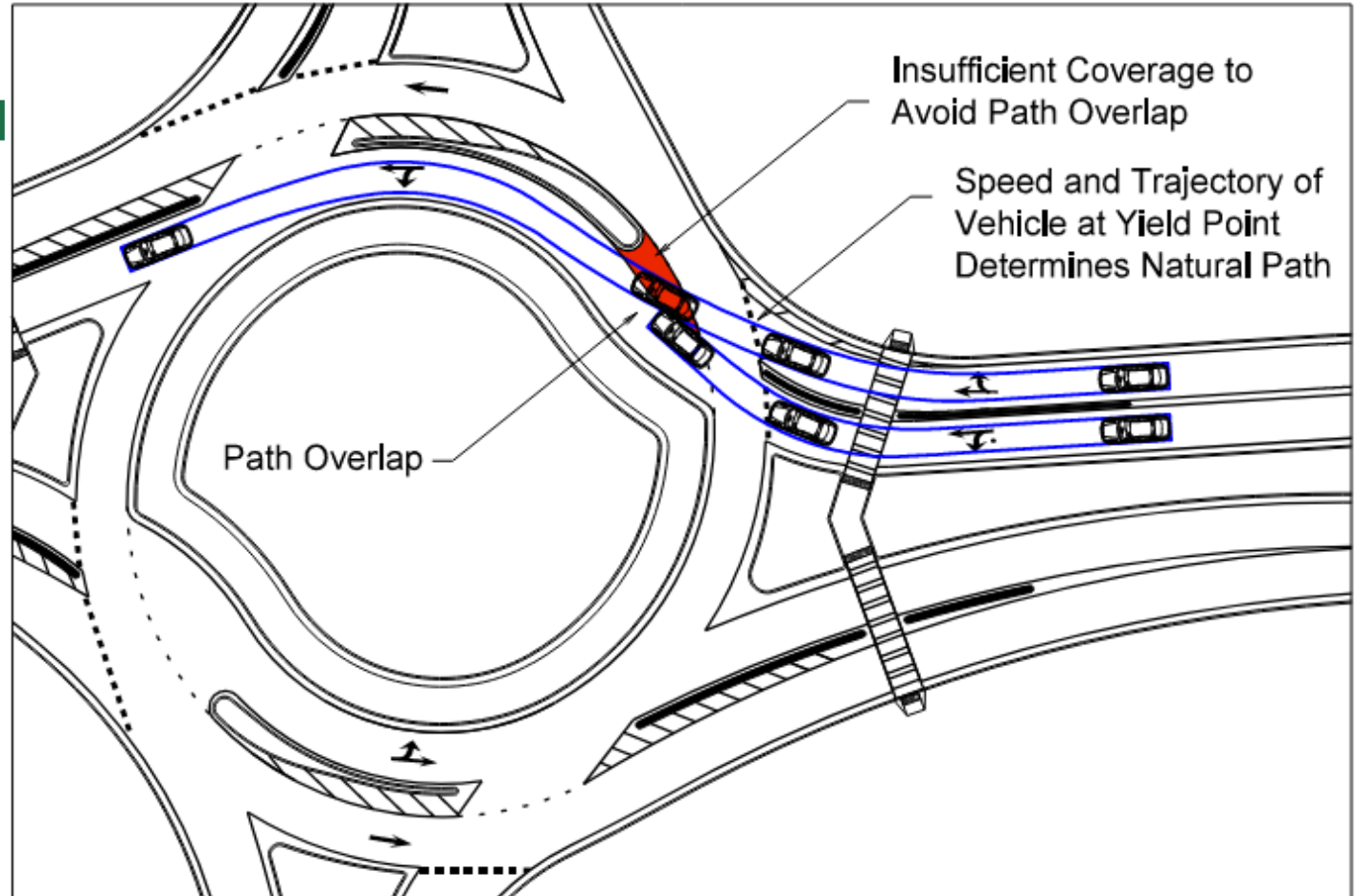
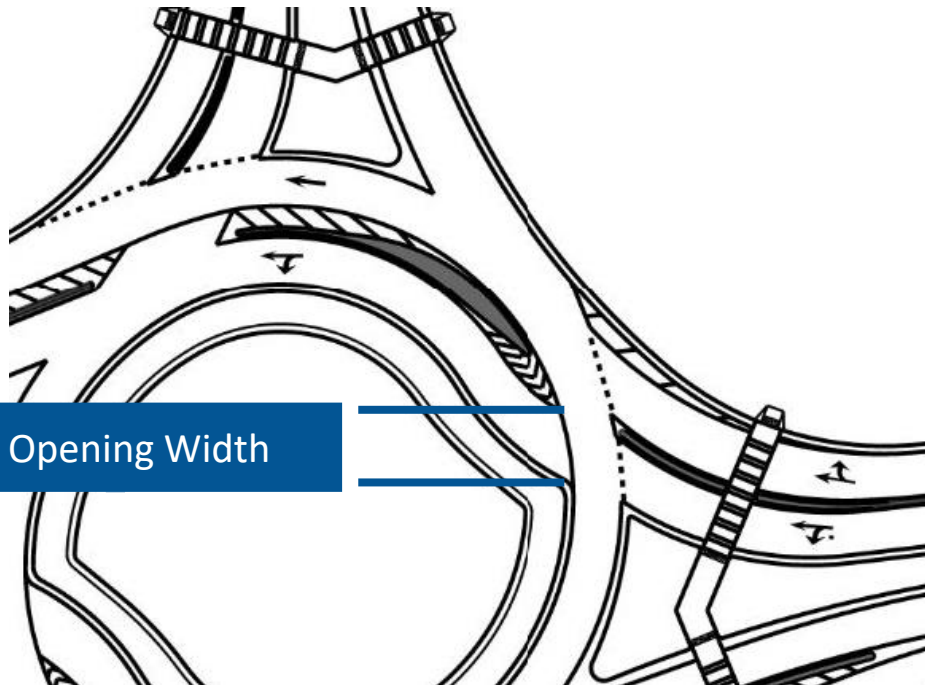

# Lane Separation

## Flush Elements – Rumble Strips

- 6" or 16"
- Milled into existing pavement
- Areas where a raised element isn't used, but want to deter changing lanes
- White stripes also used in conjunction

16"  
RUMBLE STRIPS

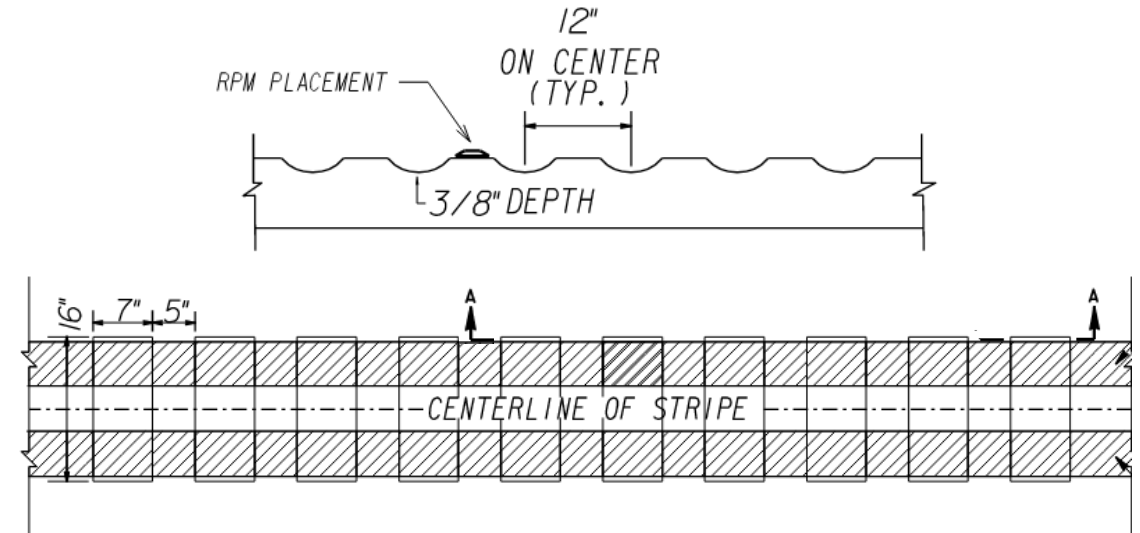

# Lane Separation

## Flush Elements – Type 8 RPMs

- 18" spacing
- White stripes also used in conjunction
- Applied to roadway surface
- Areas where you can't put in rumble strips due to pavement quality, etc.

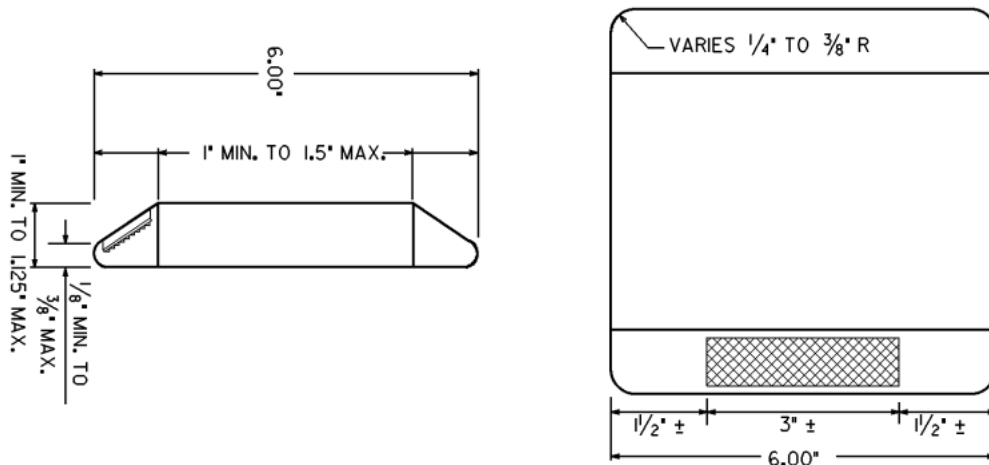

## TP 8 RPM (JIGGLE BAR) SPACING

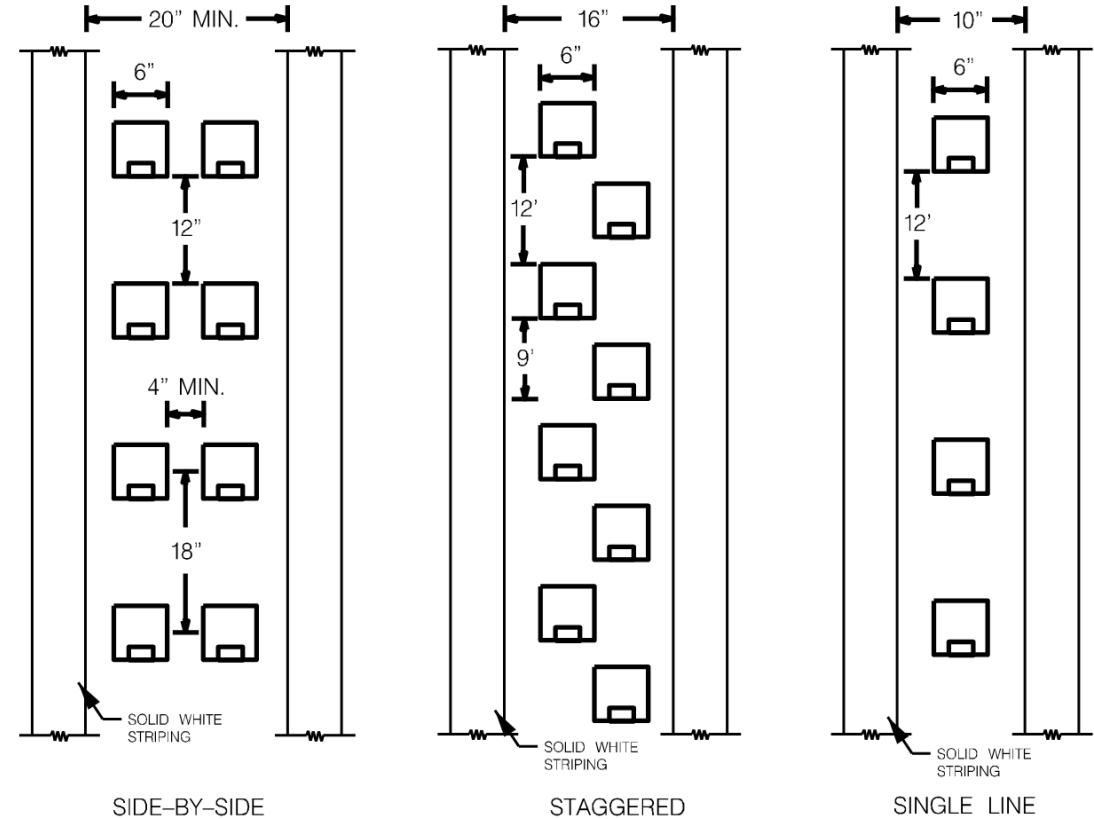

# Lane Separation

## Semi-Flush Elements

- Type 9 Modified
- Height: 2"
- Flat surface for RPM
- White stripes on both sides
- Short gaps optional for drainage

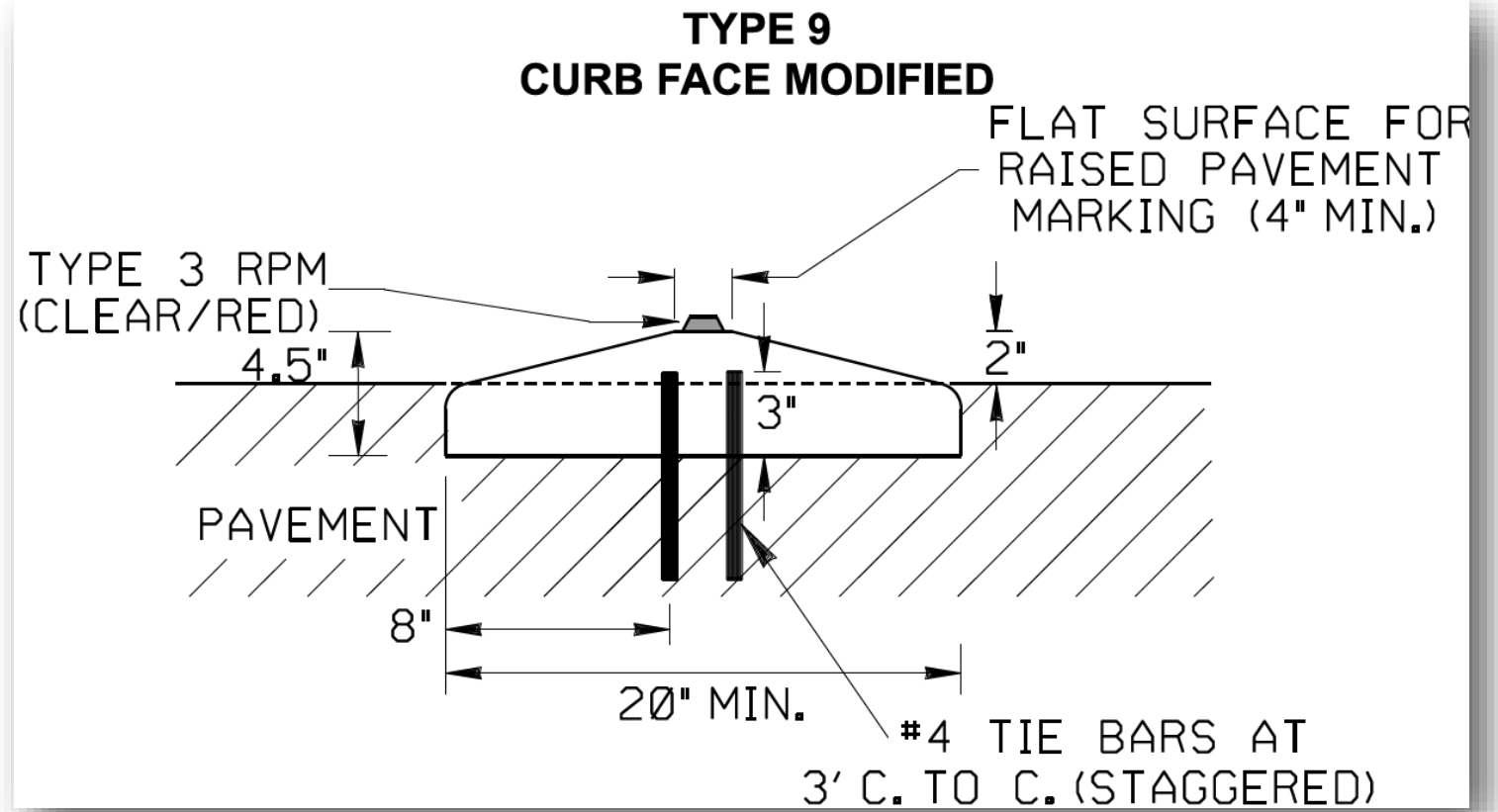

# Lane Separation

## Fastest Paths – Case 1

- Rumble strip on approach
- Rumble strip on circulatory lanes
- Rumble strip on departure lanes

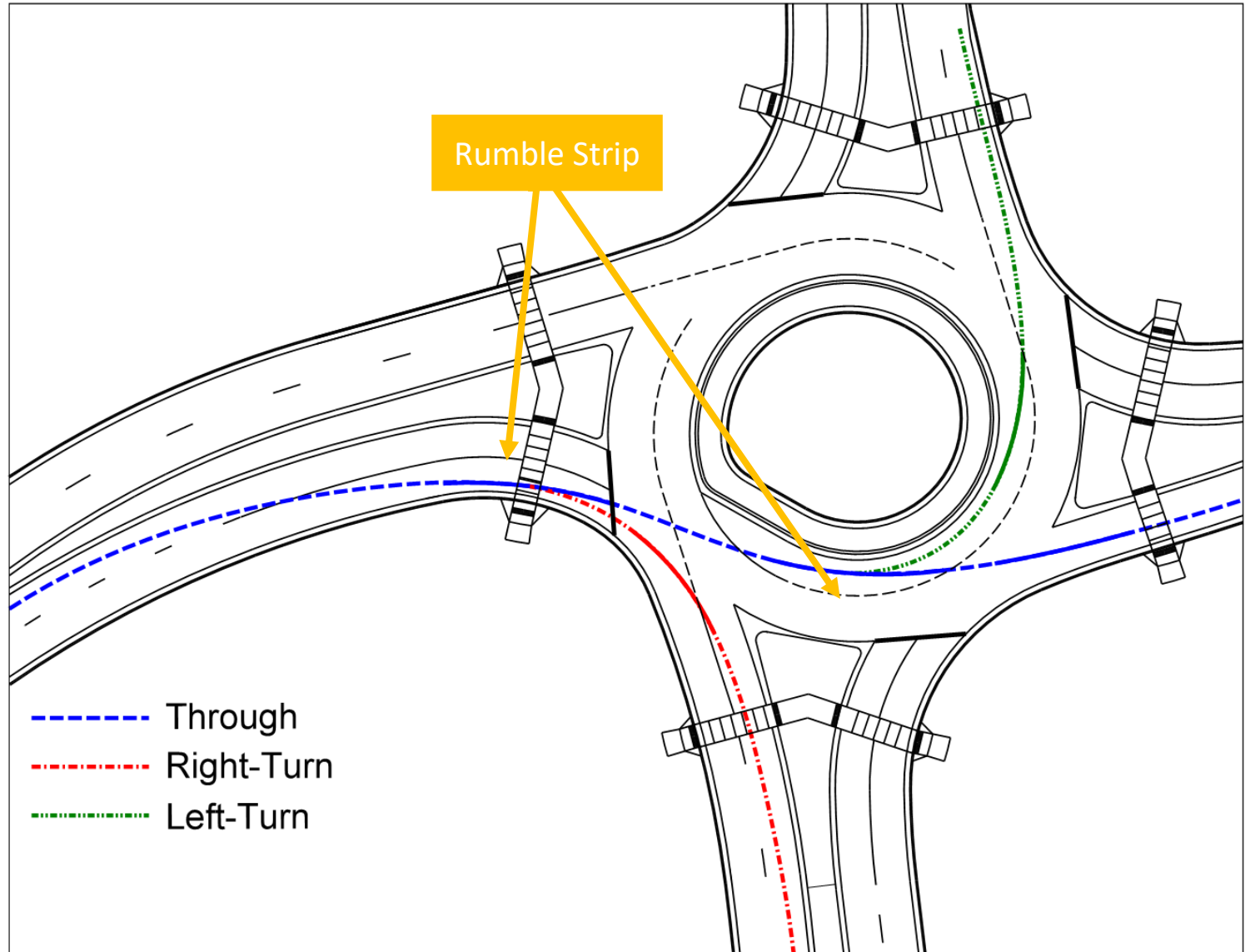

# Lane Separation

## Fastest Paths – Case 2

- Raised elements on approach
- Rumble strip on circulatory lanes
- Raised elements on departure

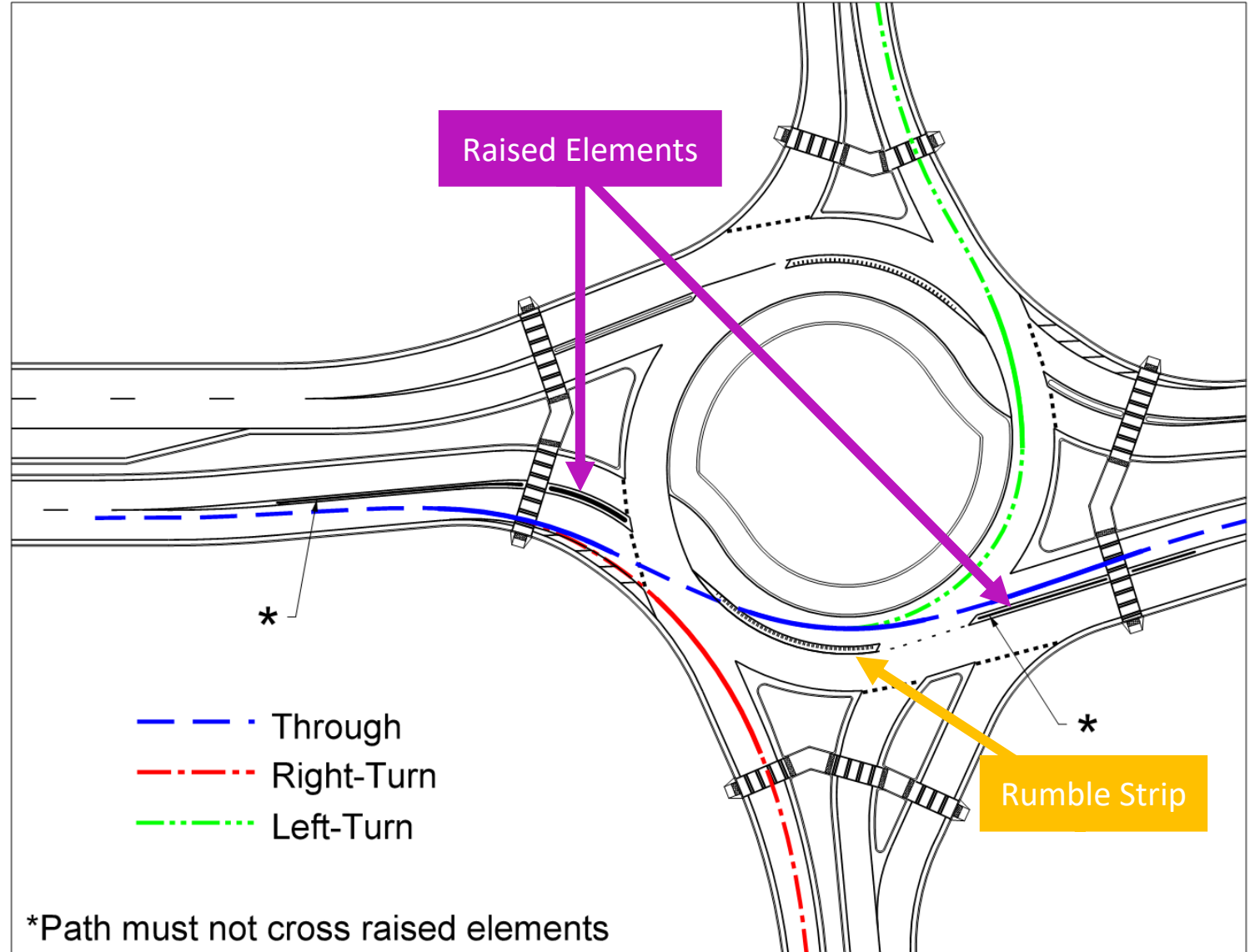

# Lane Separation

## Fastest Paths – Case 3

- Raised elements on approach
- **Raised elements** on circulatory lanes
- Raised elements on departure

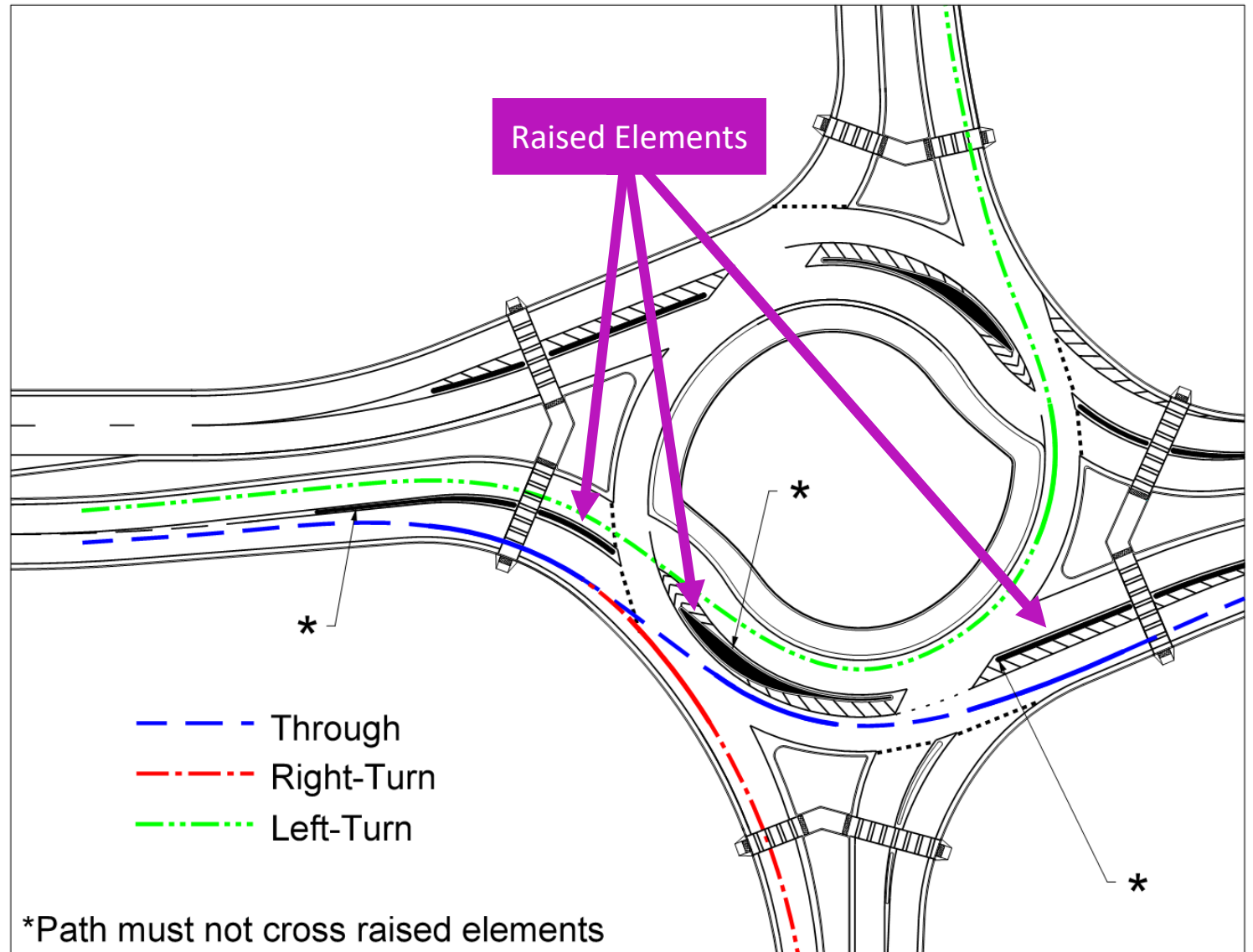

# Lane Separation

## Safety Benefits

### Lower Speeds

- Fastest Paths
- Drivers adjust speeds due to the narrower lane widths
- Less severe collisions

### Reducing Crossover Conflicts

- Fewer Side Swipe Crashes
- Mitigate Path Overlap

### Crash Statistics of 10 Multilane roundabouts in Georgia:

- Average 2.74 sideswipe crashes per year from 2019 - 2023

## Lane Separation

### Operational Benefits

Right Turning Vehicles on Minor Road

- Modern Roundabout:  
Yield for **both** circulatory lanes
- Roundabout with Raised Elements:  
Yield for **outside** circulatory lane only

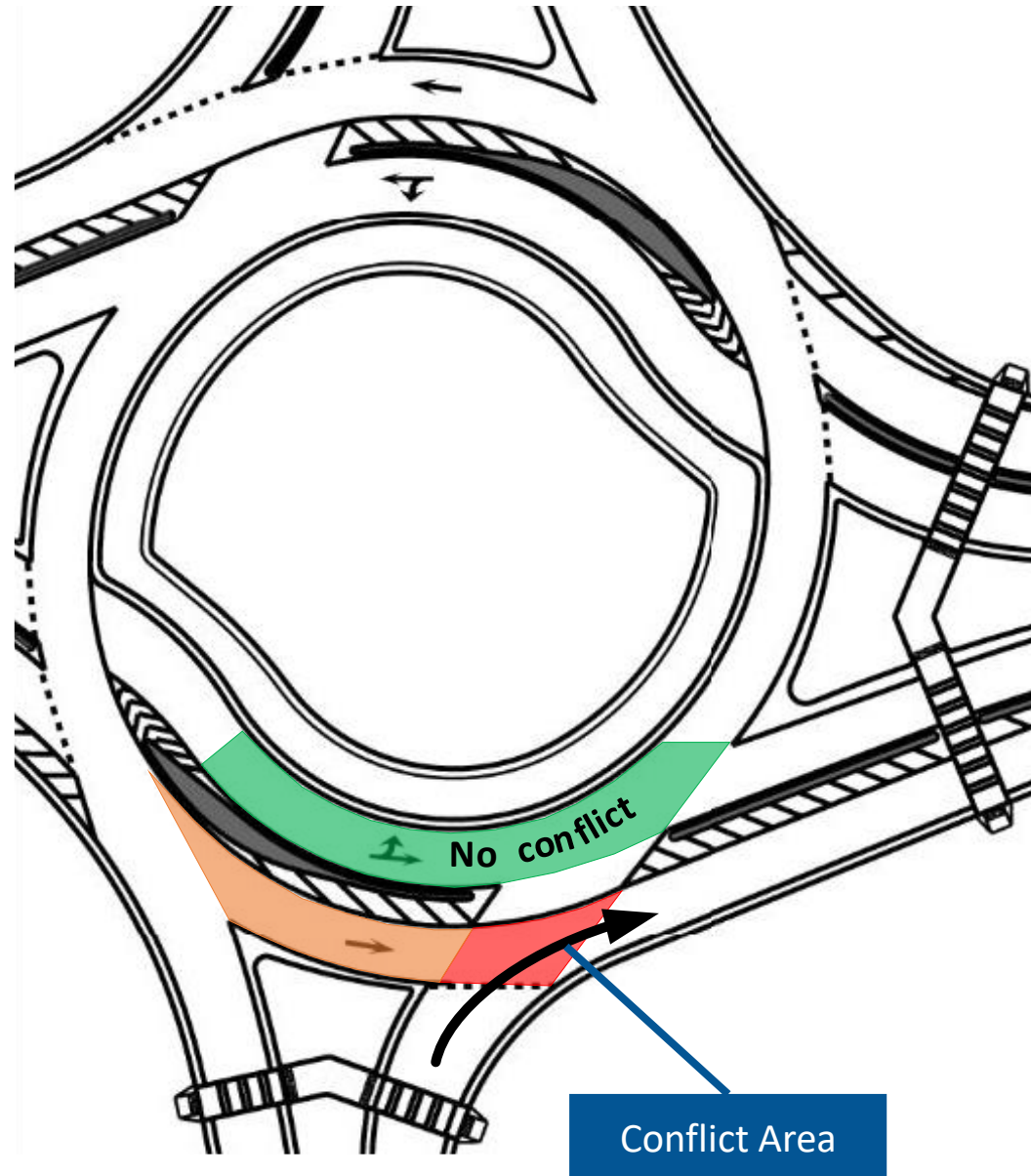

# Lane Separation

## Operational Benefits

Test in SIDRA: Percentage Opposed by Nearest Lane Only

- Volume Main Road: 100% thru
- Volume Minor Road: **one third right**
- Positive effect is depending on the volumes

Approach Selector

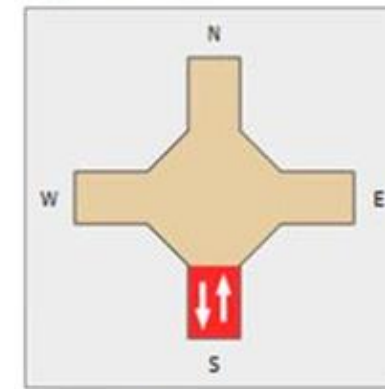

Anthony Rd NB

Gap Acceptance Data

From South to Exit:	W	N	E
	↶ L2	↑ T1	↷ R2
	Program ▾	Program ▾	Program ▾
Critical Gap			
Follow-up Headway			
Minimum Departures (vehicles per minute)	2.5	2.5	2.5
Exiting Flow Effect	0 %	0 %	0 %
<b>Percent Opposed by Nearest Lane Only</b>	<b>0.0 %</b>	<b>0.0 %</b>	<b>100.0 %</b>
Opposing Peds (Unsig)	Prg(Flow ▾	Prg(Flow ▾	Prg(Flow ▾

Reduction Delay on the Minor Road		Minor Volume			
		300 veh.	450 veh.	600 veh.	750 veh.
Main Volume	1,000 veh.	4.3%	6.5%	9.8%	14.8%
	1,250 veh.	3.8%	5.5%	9.3%	11.5%
	1,500 veh.	3.3%	4.8%	8.0%	7.4%

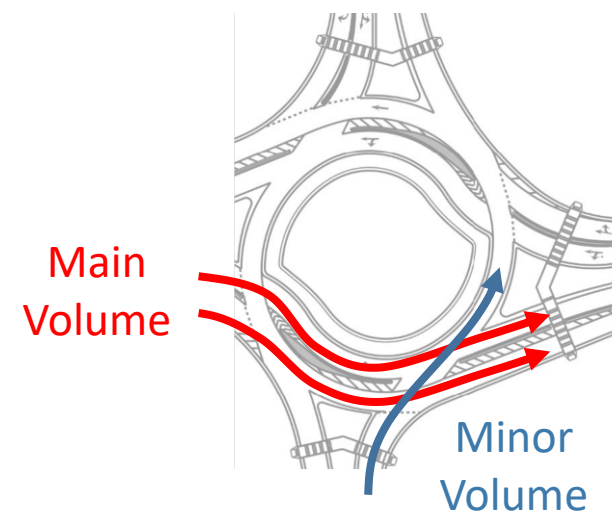

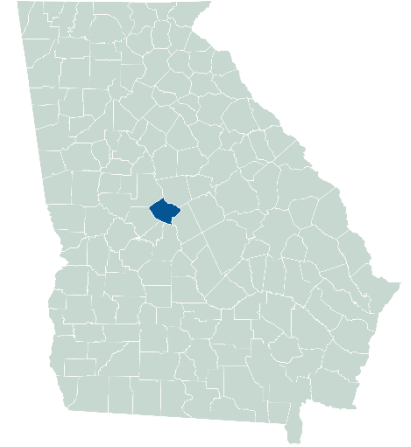

# Case Study 1

## City of Macon, Bibb County

### SR 74 at Anthony Rd

## Case Studies – City of Macon, Bibb County

### SR 74 at Anthony Rd / Burton Ave / Columbus Rd, **Safety Project (PI 0017394)**

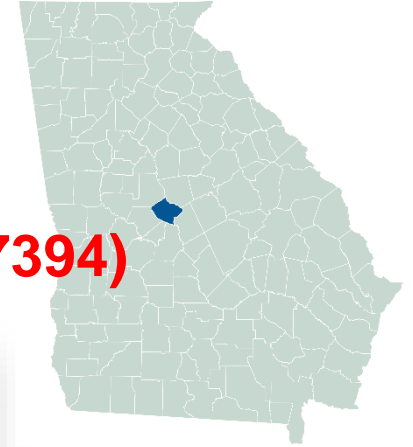

411 crashes in 5 years

- PDO: 263
- Injury: 146
- Fatal: 2



# Case Studies – City of Macon, Bibb County

SR 74 at Anthony Rd / Burton Ave / Columbus Rd, **Safety Project (PI 0017394)**

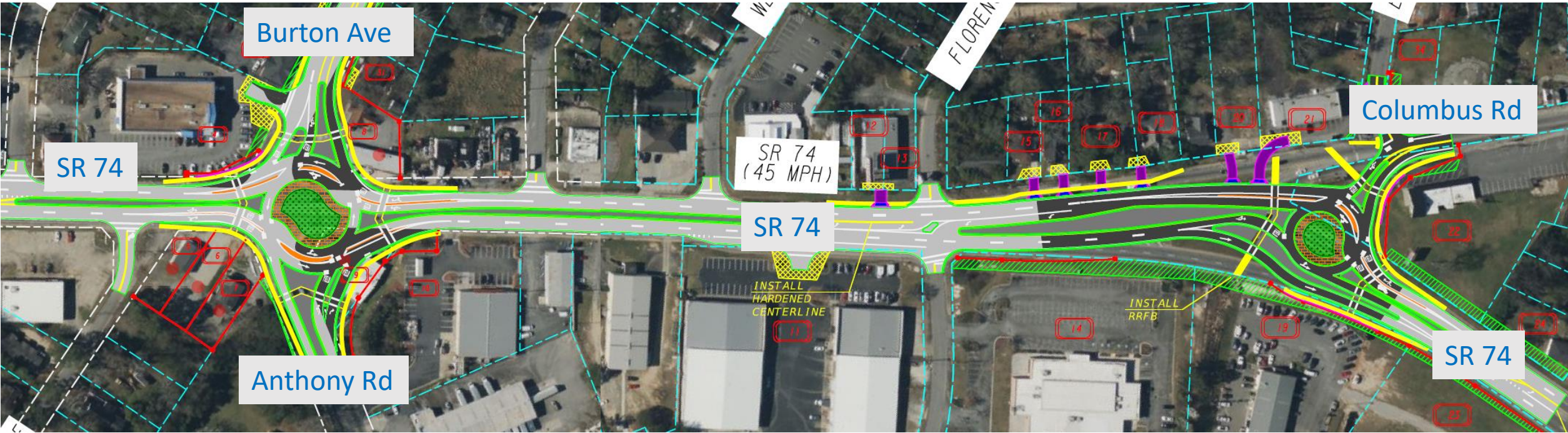
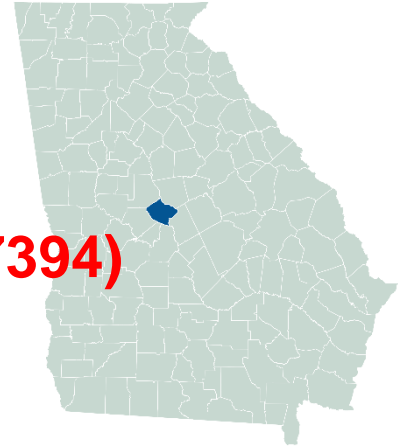

# Case Studies – City of Macon, Bibb County

## SR 74 at Anthony Rd / Burton Ave / Columbus Rd, Safety Project (PI 0017394)

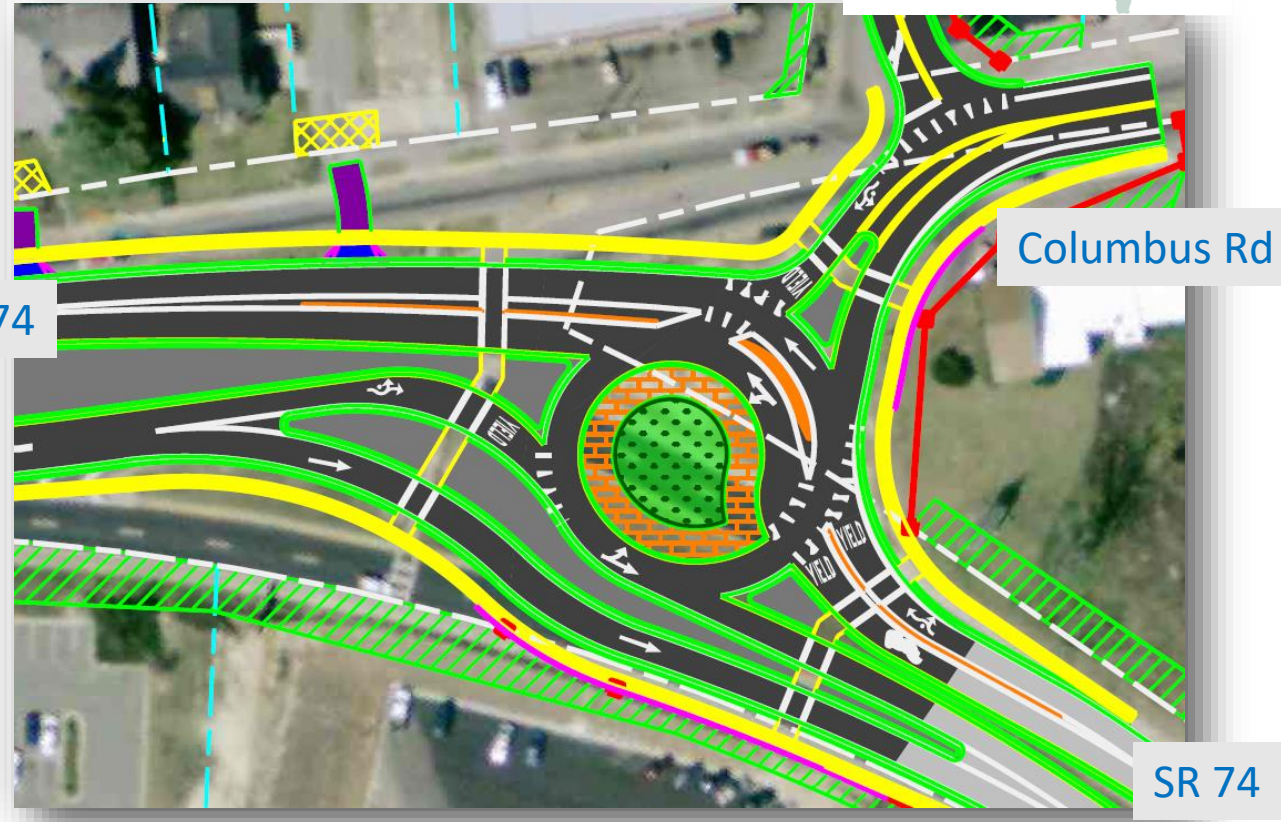
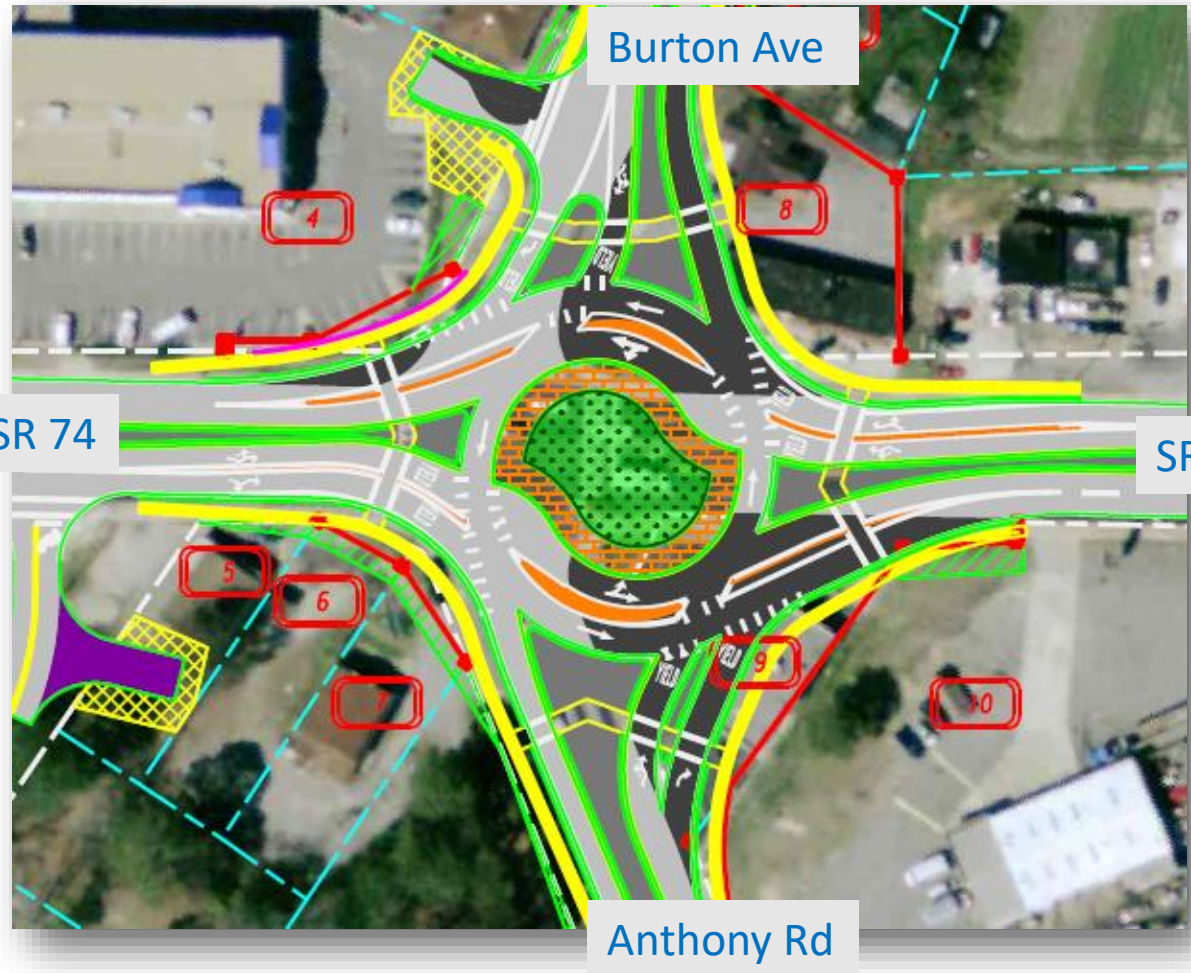
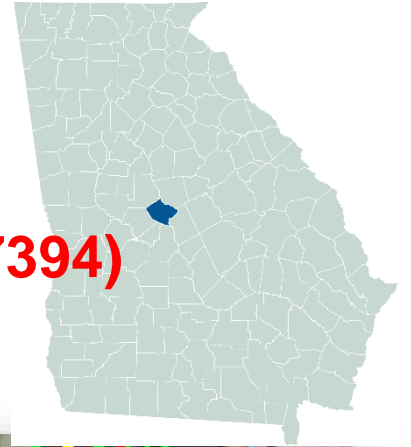

## Case Studies – City of Macon, Bibb County

**SR 74 at Anthony Rd / Burton Ave / Columbus Rd, Safety Project (PI 0017394)**

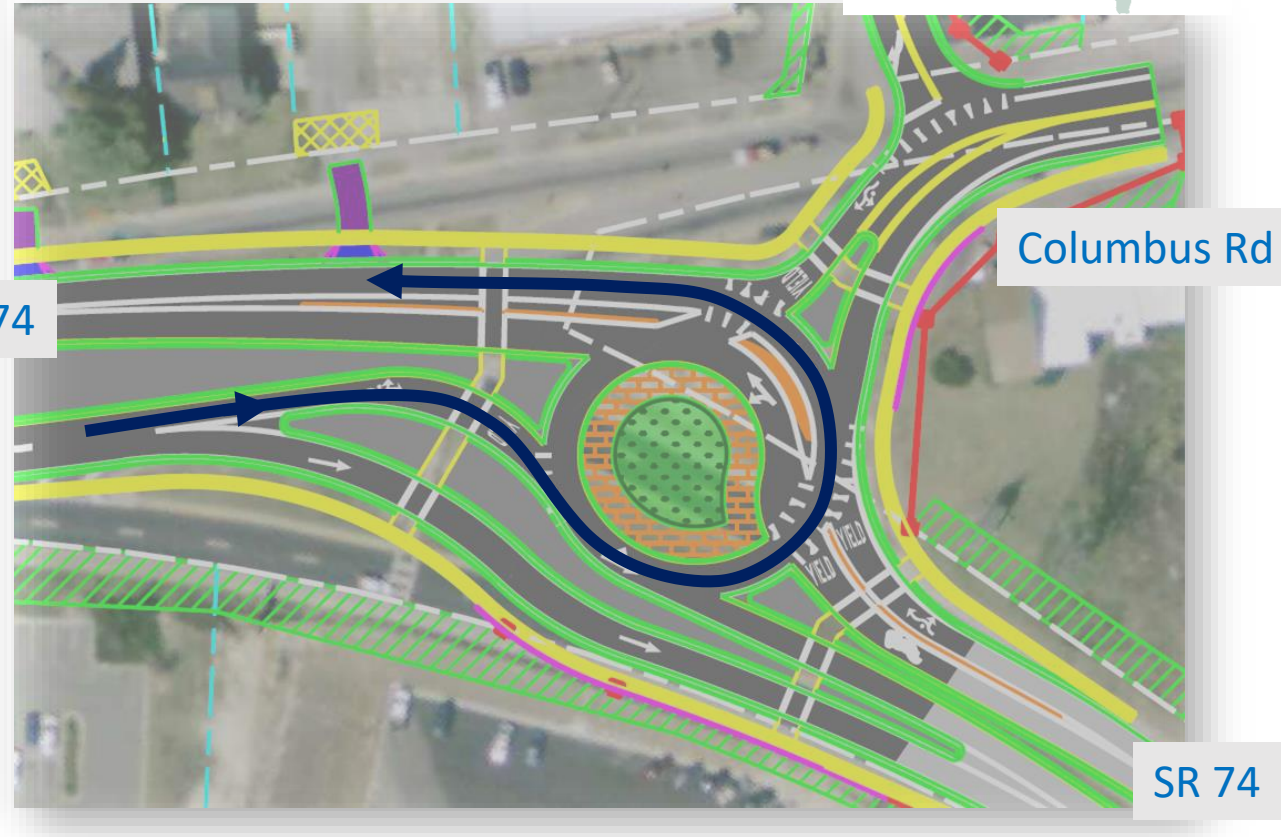
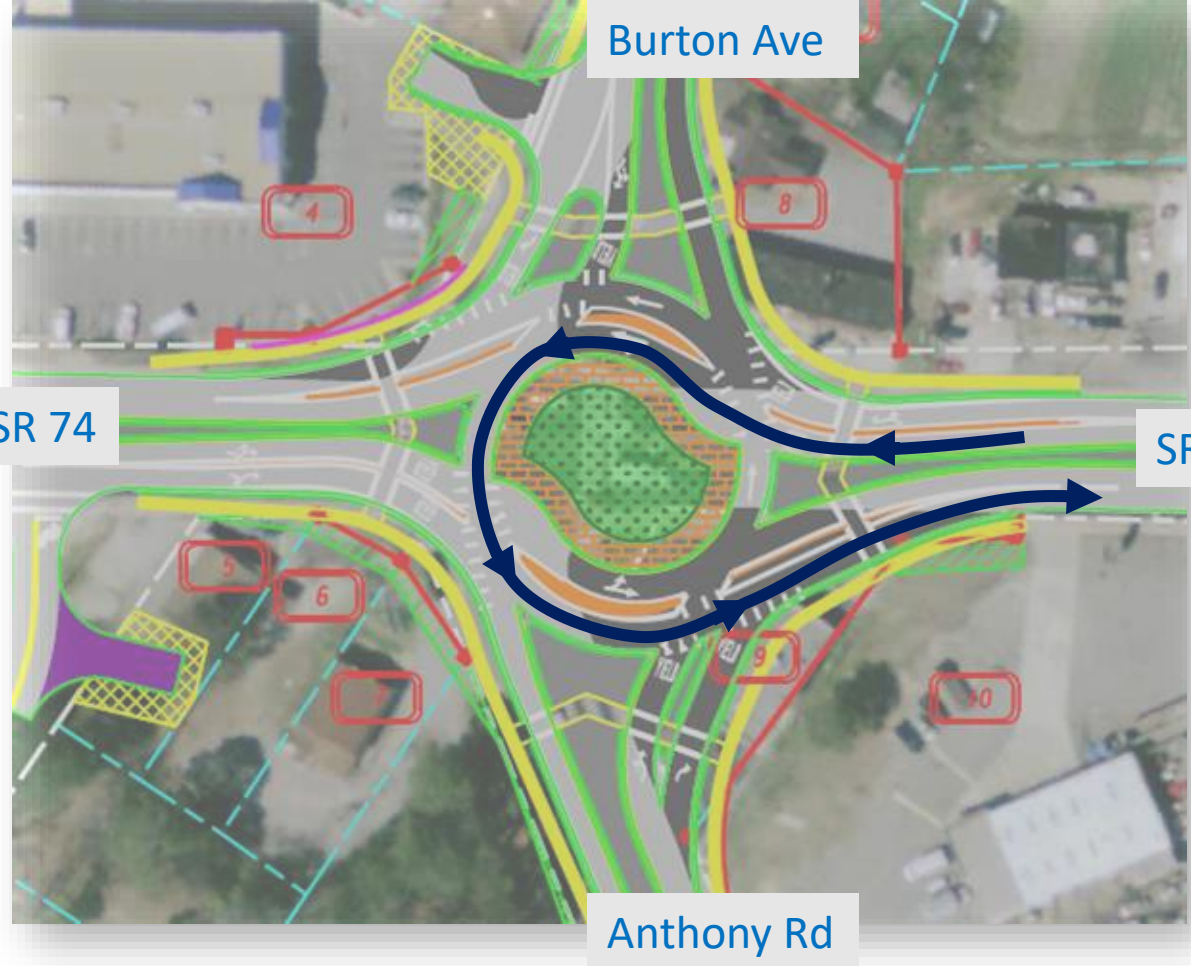
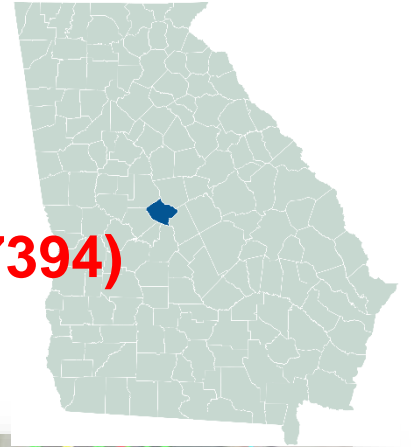

## Case Studies – City of Macon, Bibb County

SR 74 at Anthony Rd / Burton Ave / Columbus Rd, **Safety Project (PI 0017394)**

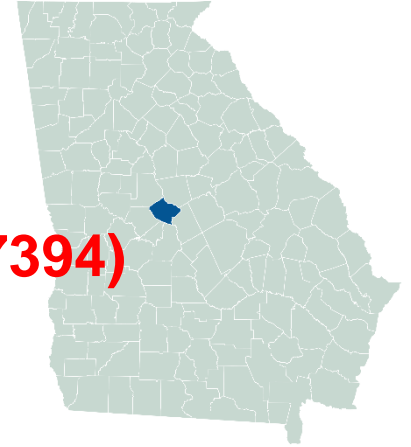

- Case 3 roundabout
- WB 67 side by side
- Modern Roundabout: 21 ft lane

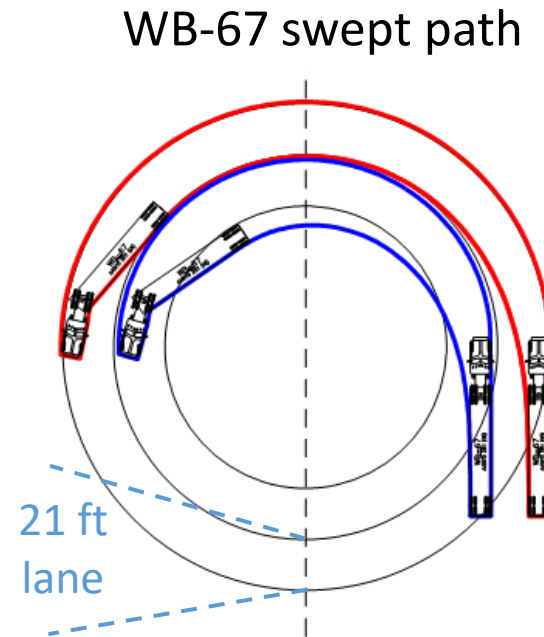

## Case Studies – City of Macon, Bibb County

### SR 74 at Anthony Rd / Burton Ave / Columbus Rd, **Safety Project (PI 0017394)**

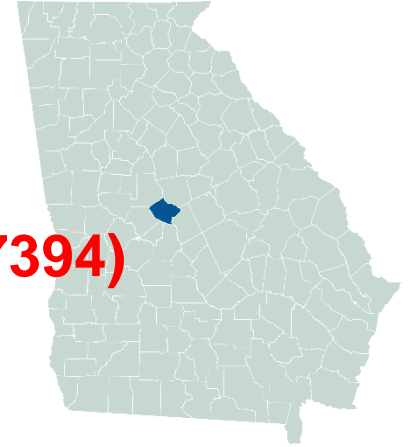

- Case 3 roundabout
- WB 67 side by side
- Modern Roundabout: 21 ft lane
- Bus needs only 14 ft

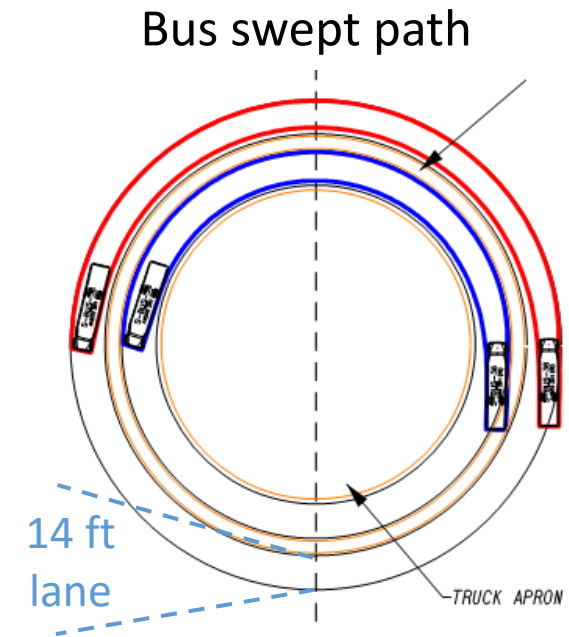
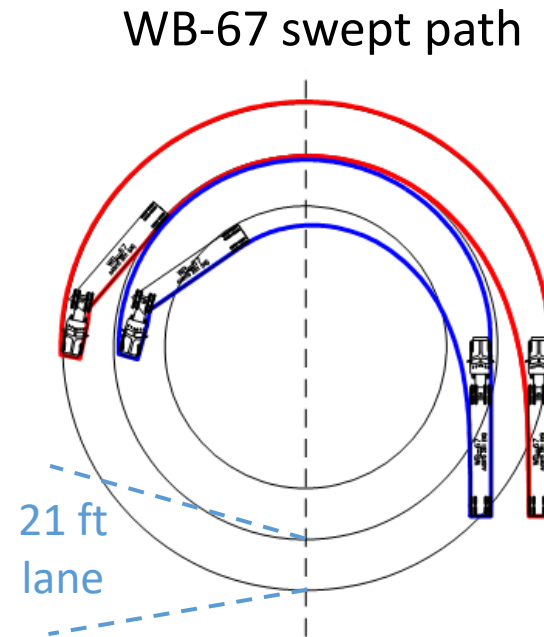

## Case Studies – City of Macon, Bibb County

### SR 74 at Anthony Rd / Burton Ave / Columbus Rd, **Safety Project (PI 0017394)**

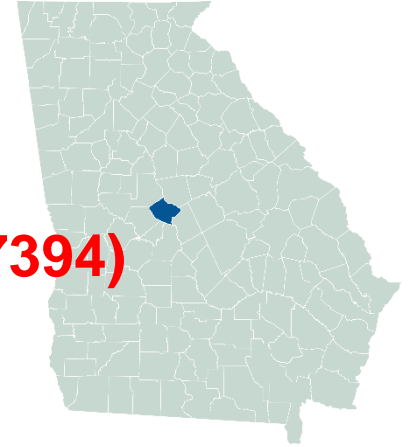

- Case 3 roundabout
- WB 67 side by side
- Modern Roundabout: 21 ft lane
- Bus needs only 14 ft
- **Solution: Raised Lane Separation**

WB-67 swept path

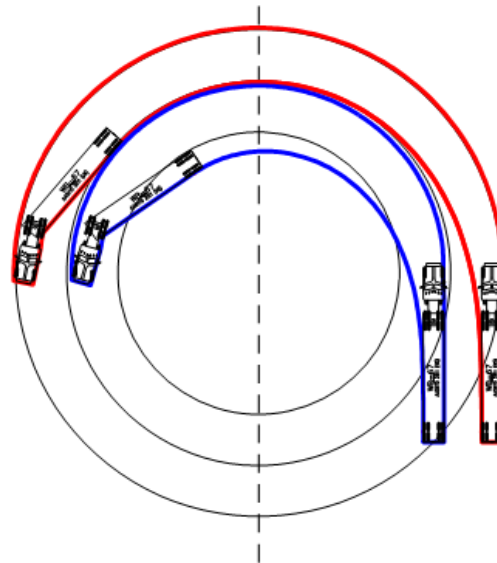

Bus swept path

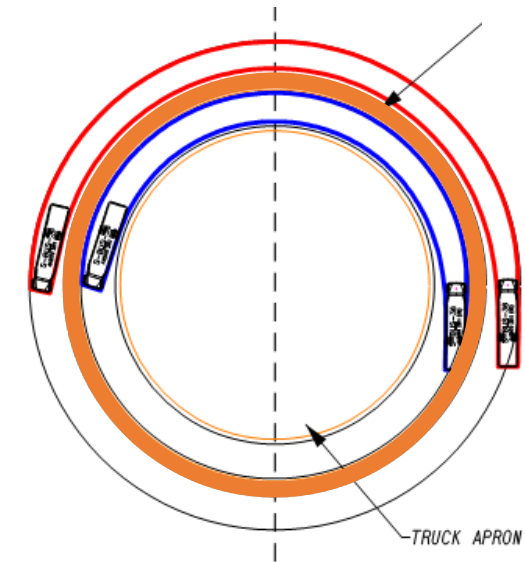

Proposed  
Raised Lane  
Separation

## Case Studies – City of Macon, Bibb County

### SR 74 at Anthony Rd / Burton Ave / Columbus Rd, Safety Project (PI 0017394)

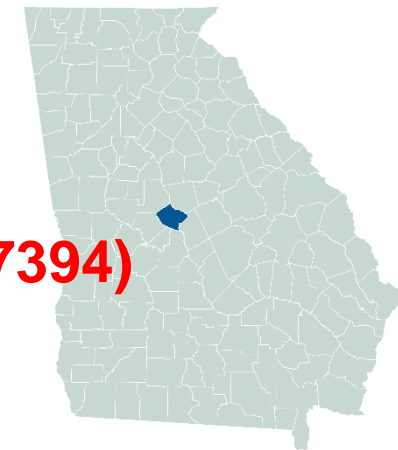

- Case 3 roundabout
- WB 67 side by side
- Modern Roundabout: 21 ft lane
- For bus only 14 ft needed
- Proposed Raised Lane Separation
- **For Spiral: shift and rotate**

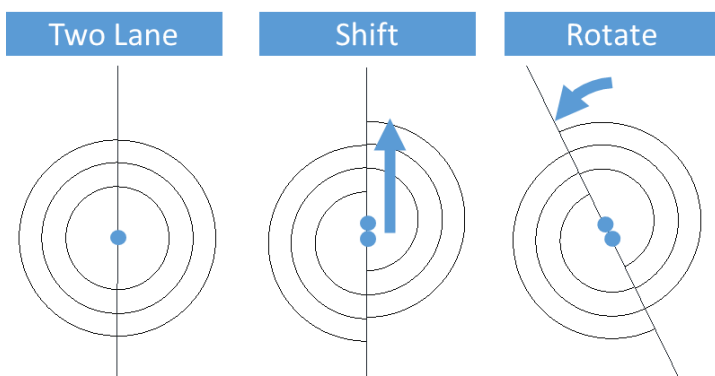

WB-67 swept path

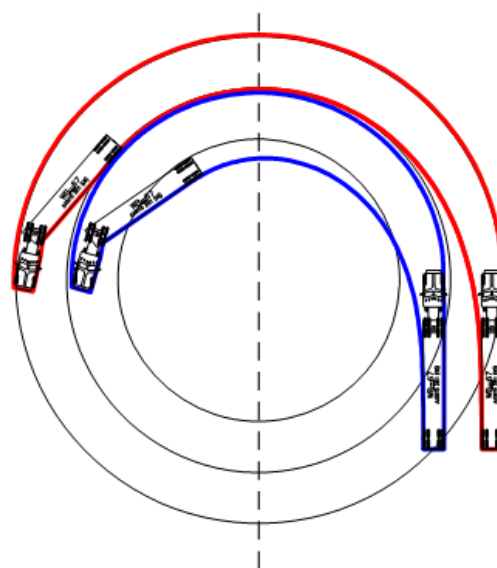

Bus swept path

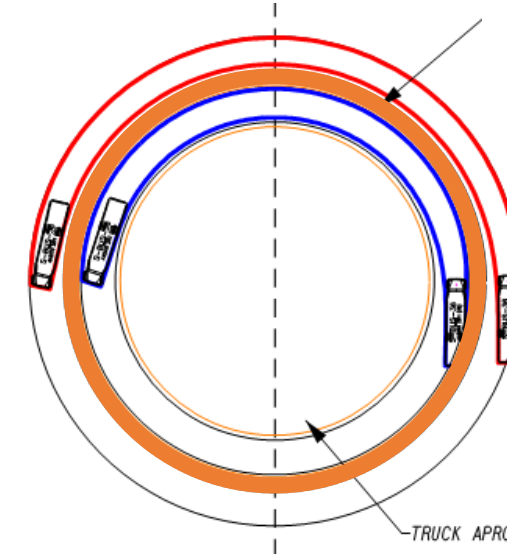

Proposed  
Raised Lane  
Separation

# Case Studies – City of Macon, Bibb County

SR 74 at Anthony Rd / Burton Ave / Columbus Rd, **Safety Project (PI 0017394)**

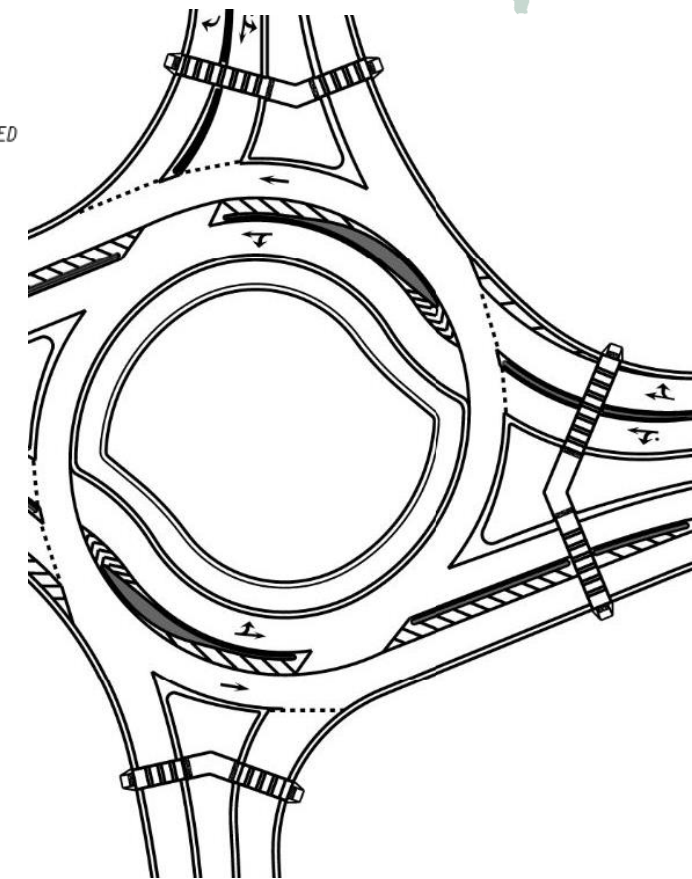
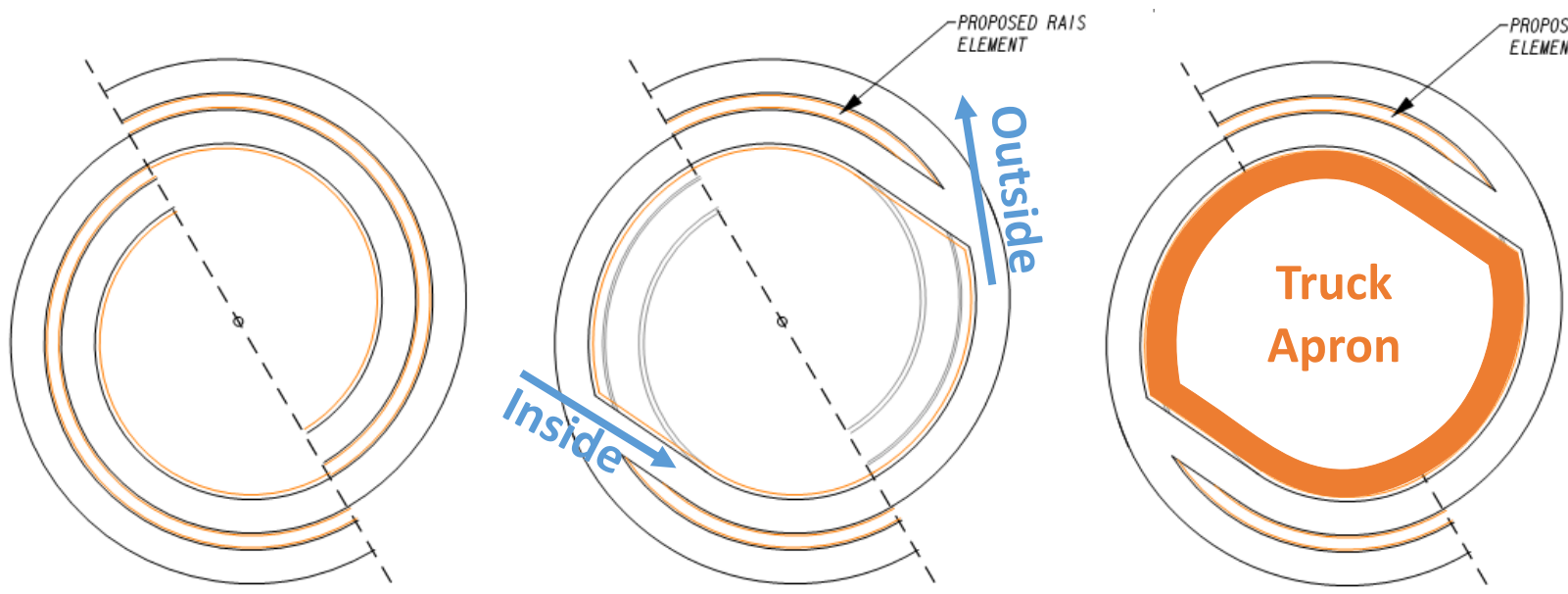
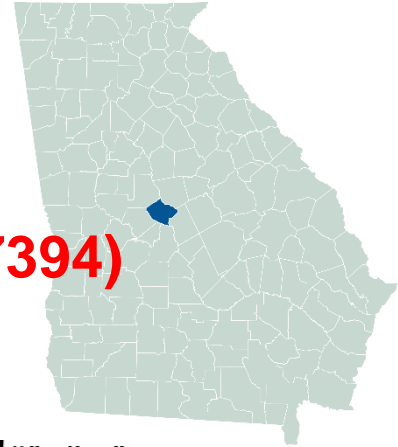

# Case Studies – City of Macon, Bibb County

SR 74 at Anthony Rd / Burton Ave / Columbus Rd, **Safety Project (PI 0017394)**

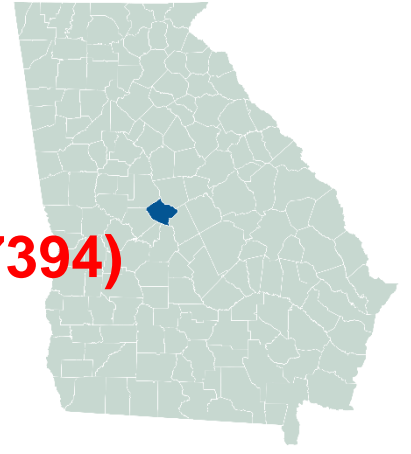

Case 1: 27 mph

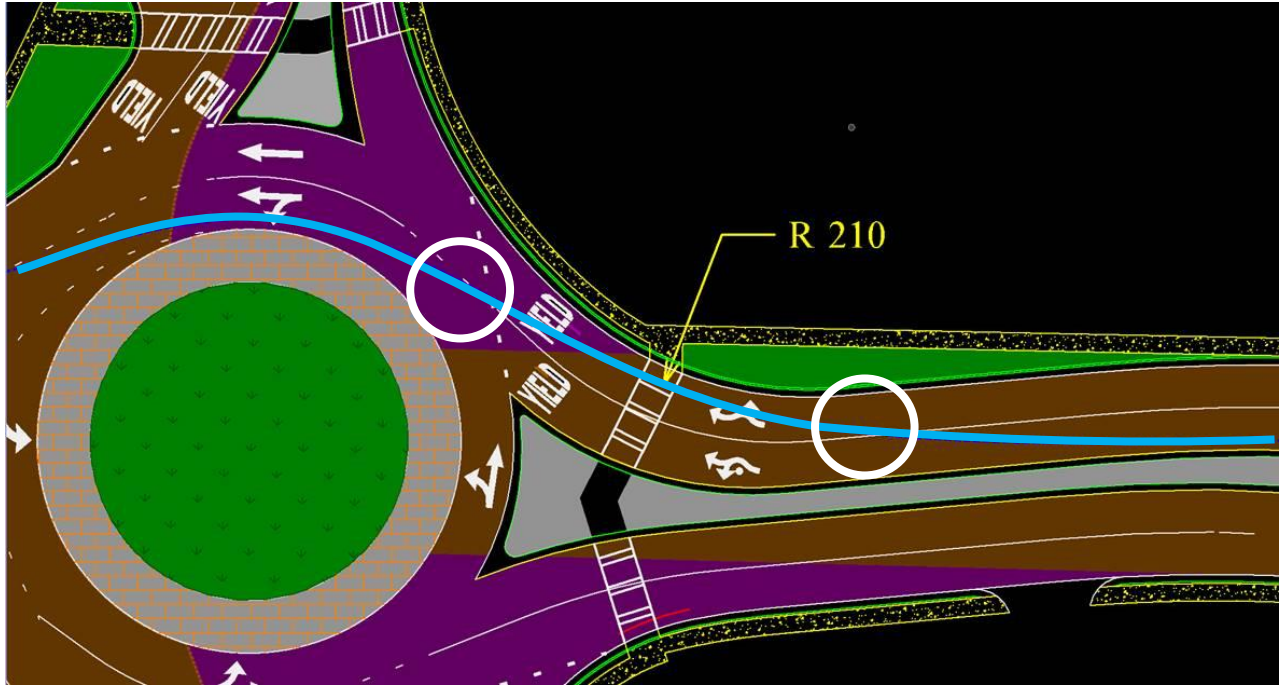

Case 3: 22 mph

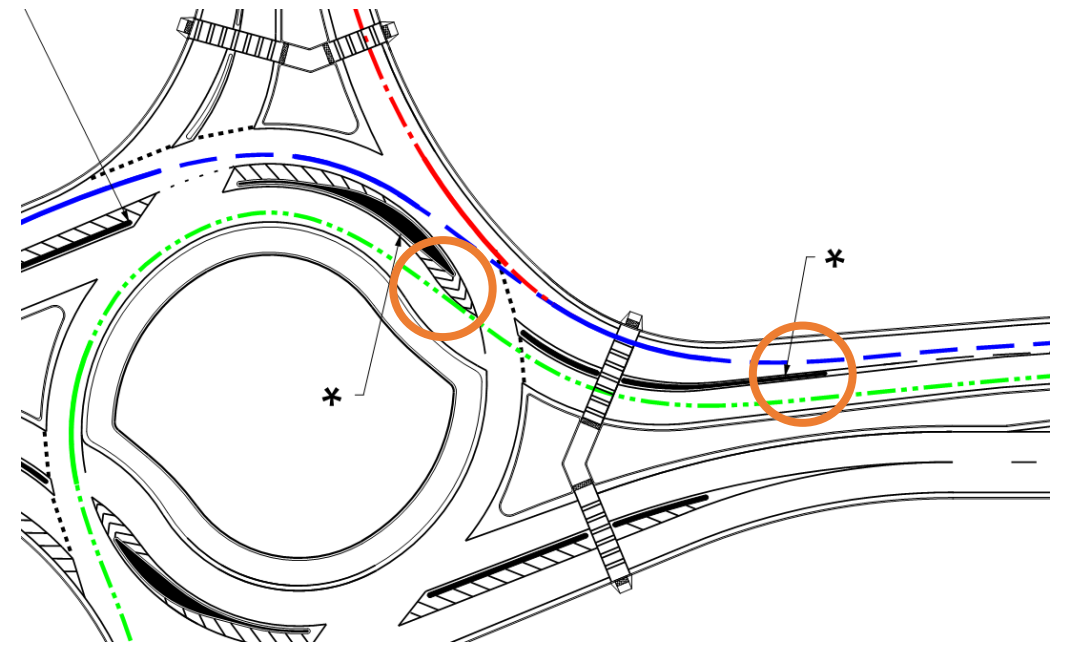

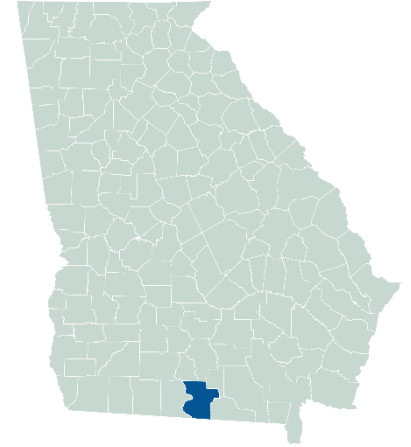

# Case Study 2

## City of Valdosta, Lowndes County

### SR 7 at Smithbriar Dr

# Case Studies – City of Valdosta, Lowndes County

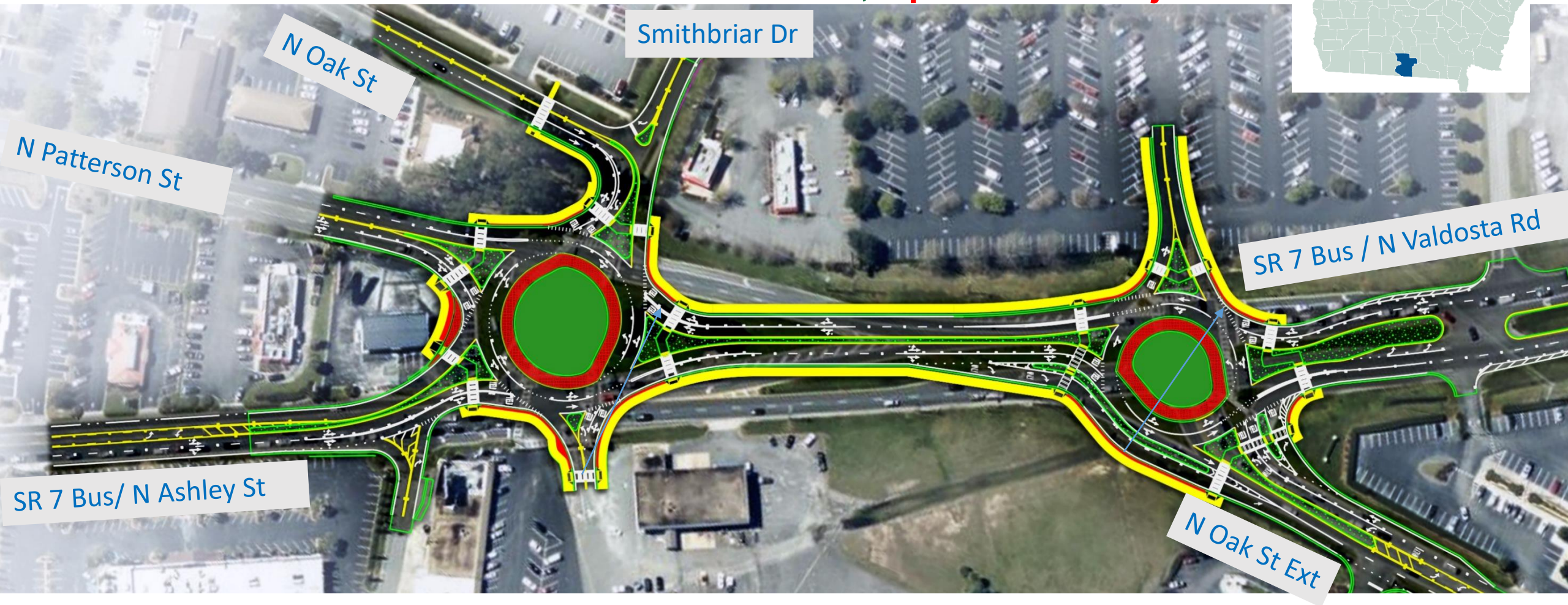

**SR 7 @ Smithbriar Dr / N Patterson / N Oak St, Operational Project PI 0015445**

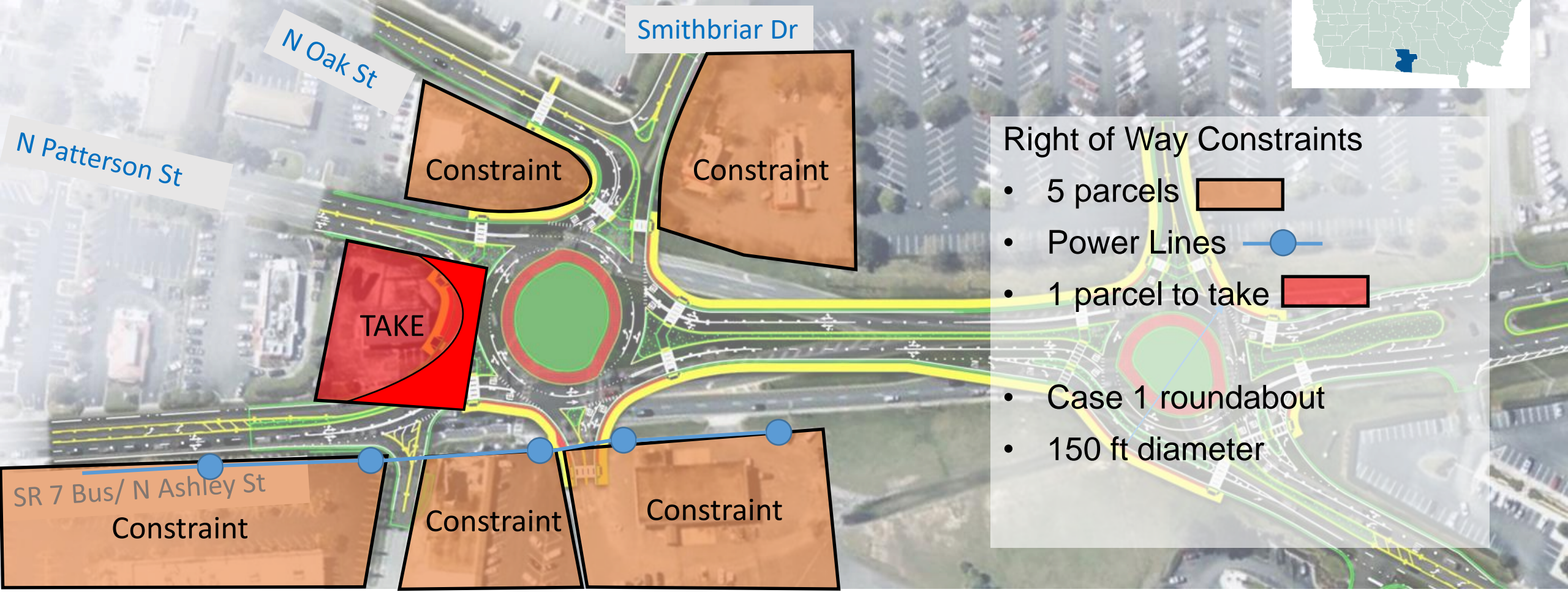
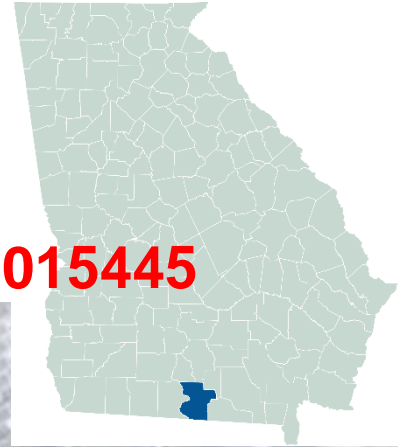

# Case Studies – City of Valdosta, Lowndes County

## SR 7 @ Smithbriar Dr / N Patterson / N Oak St, **Operational Project PI 0015445**

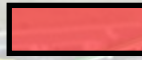

- Right of Way Constraints**
- 5 parcels 
  - Power Lines 
  - 1 parcel to take 
  - Case 1 roundabout
  - 150 ft diameter

## Case Studies – City of Valdosta, Lowndes County

SR 7 @ Smithbriar Dr / N Patterson / N Oak St, **Operational Project PI 0015445**

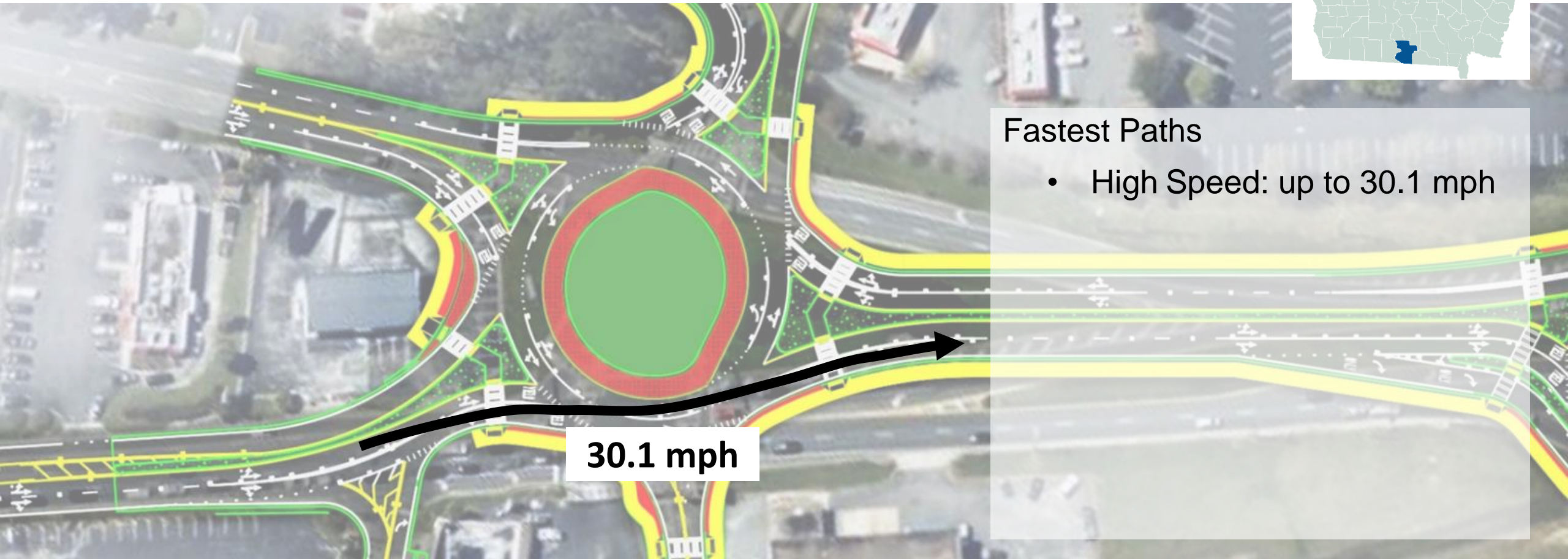

Fastest Paths

- High Speed: up to 30.1 mph

## Case Studies – City of Valdosta, Lowndes County

SR 7 @ Smithbriar Dr / N Patterson / N Oak St, **Operational Project PI 0015445**

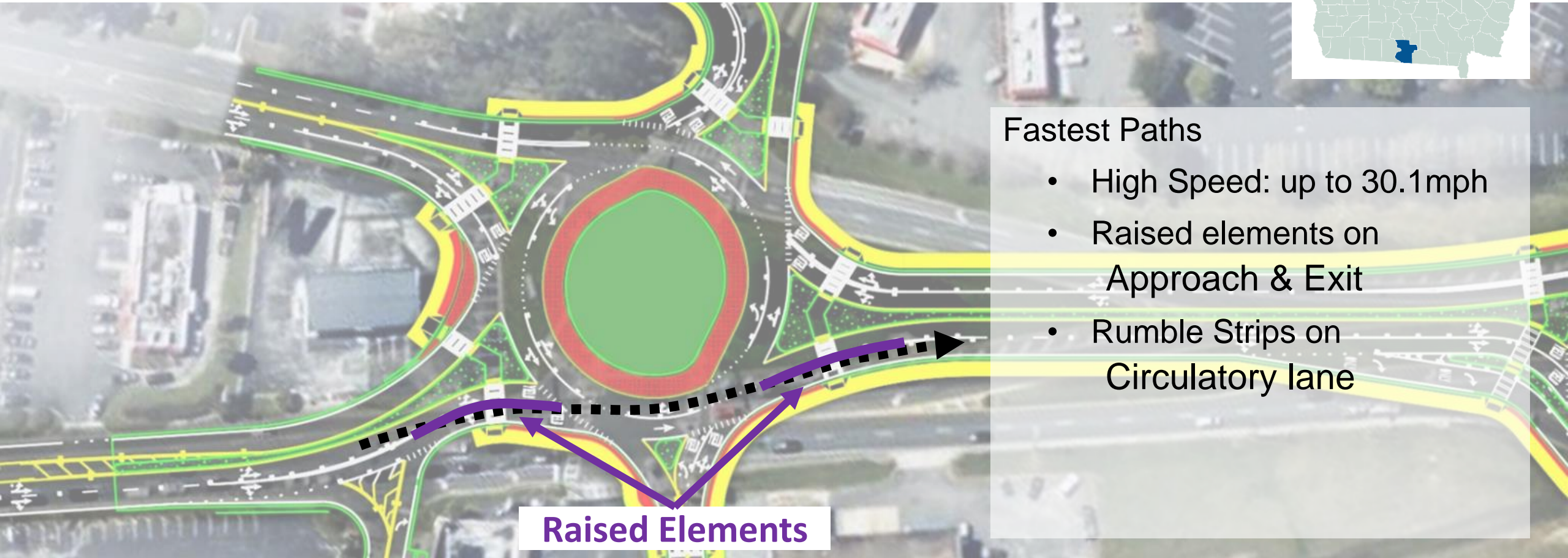

### Fastest Paths

- High Speed: up to 30.1 mph
- Raised elements on Approach & Exit
- Rumble Strips on Circulatory lane

**Raised Elements**

## Case Studies – City of Valdosta, Lowndes County

SR 7 @ Smithbriar Dr / N Patterson / N Oak St, **Operational Project PI 0015445**

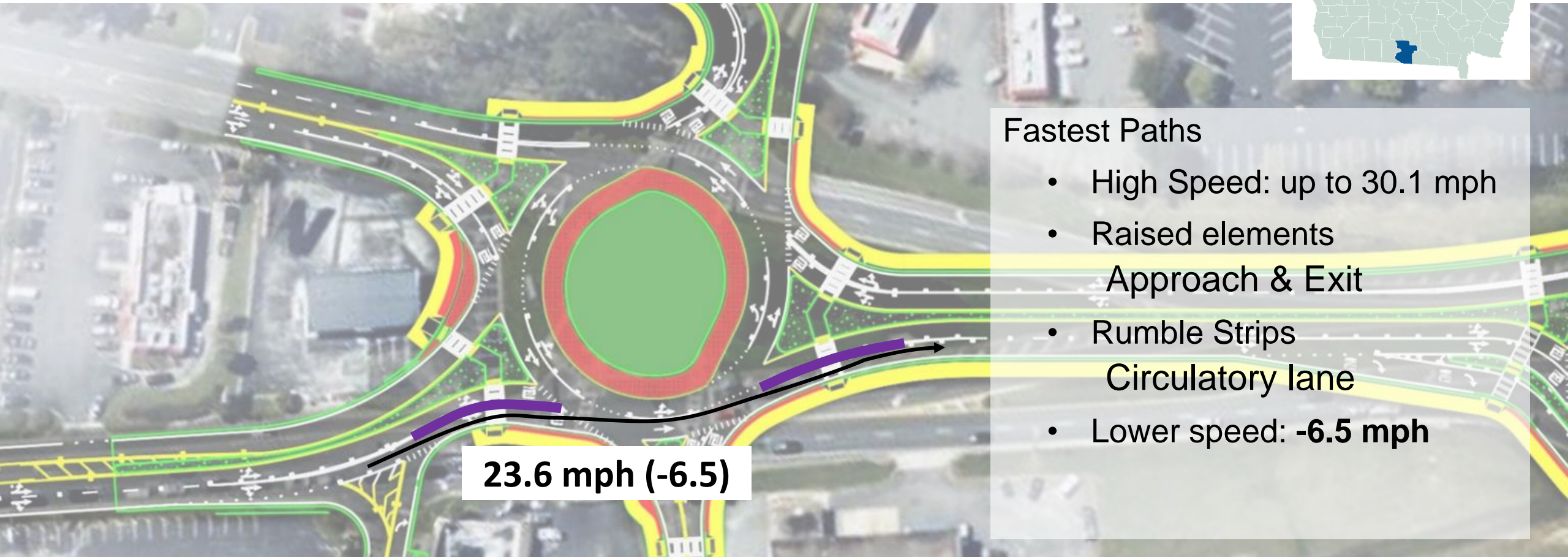

**Fastest Paths**

- High Speed: up to 30.1 mph
- Raised elements  
Approach & Exit
- Rumble Strips  
Circulatory lane
- Lower speed: -6.5 mph

## Case Studies – City of Valdosta, Lowndes County

SR 7 @ Smithbriar Dr / N Patterson / N Oak St, **Operational Project PI 0015445**

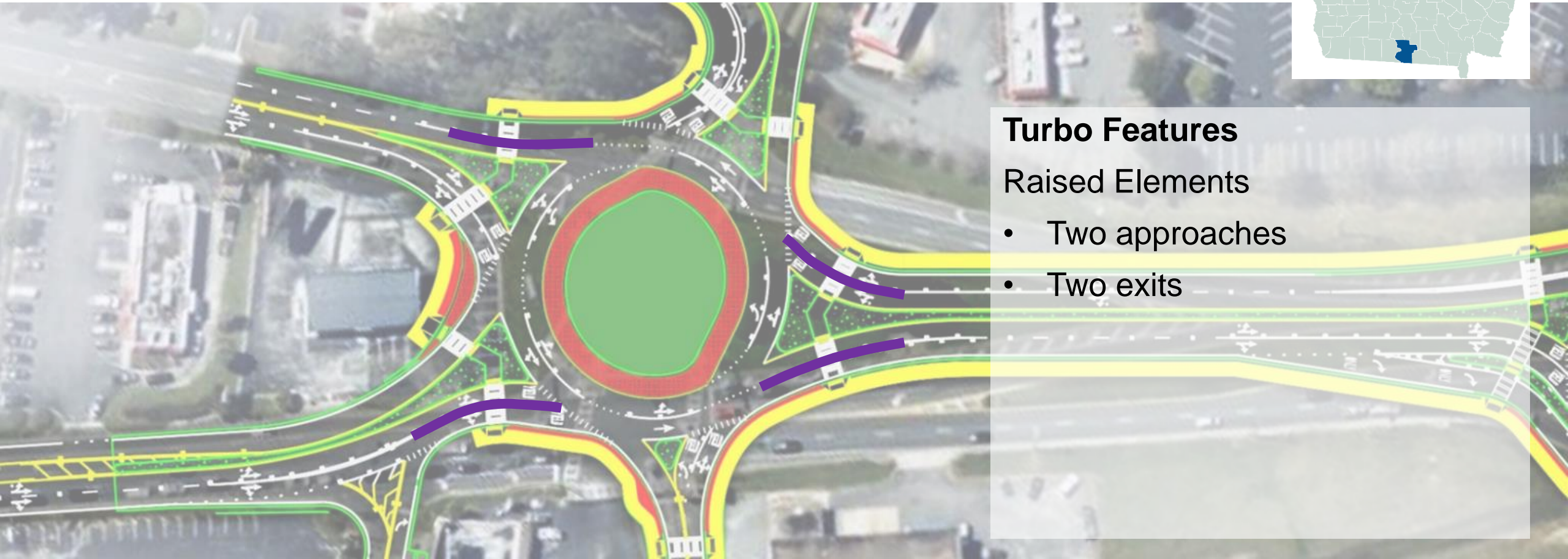

### **Turbo Features**

Raised Elements

- Two approaches
- Two exits

## Case Studies – City of Valdosta, Lowndes County

SR 7 @ Smithbriar Dr / N Patterson / N Oak St, **Operational Project PI 0015445**

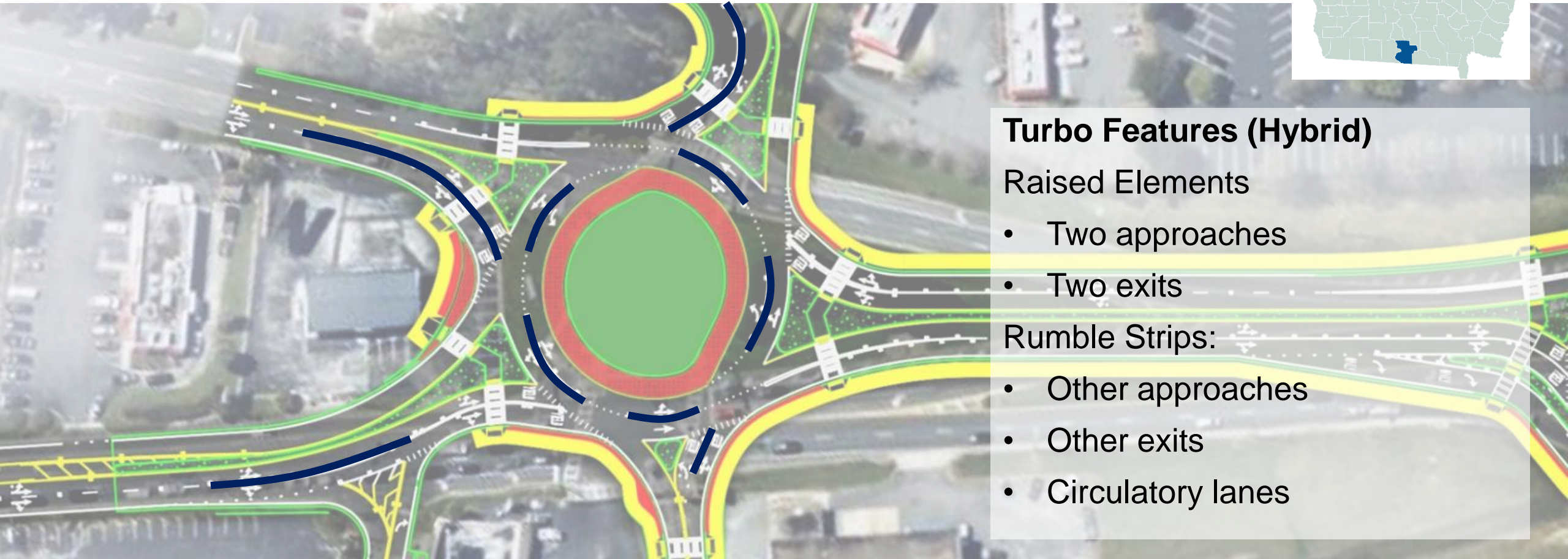

### **Turbo Features (Hybrid)**

Raised Elements

- Two approaches
- Two exits

Rumble Strips:

- Other approaches
- Other exits
- Circulatory lanes

## Case Studies – City of Valdosta, Lowndes County

SR 7 @ Smithbriar Dr / N Patterson / N Oak St, **Operational Project PI 0015445**

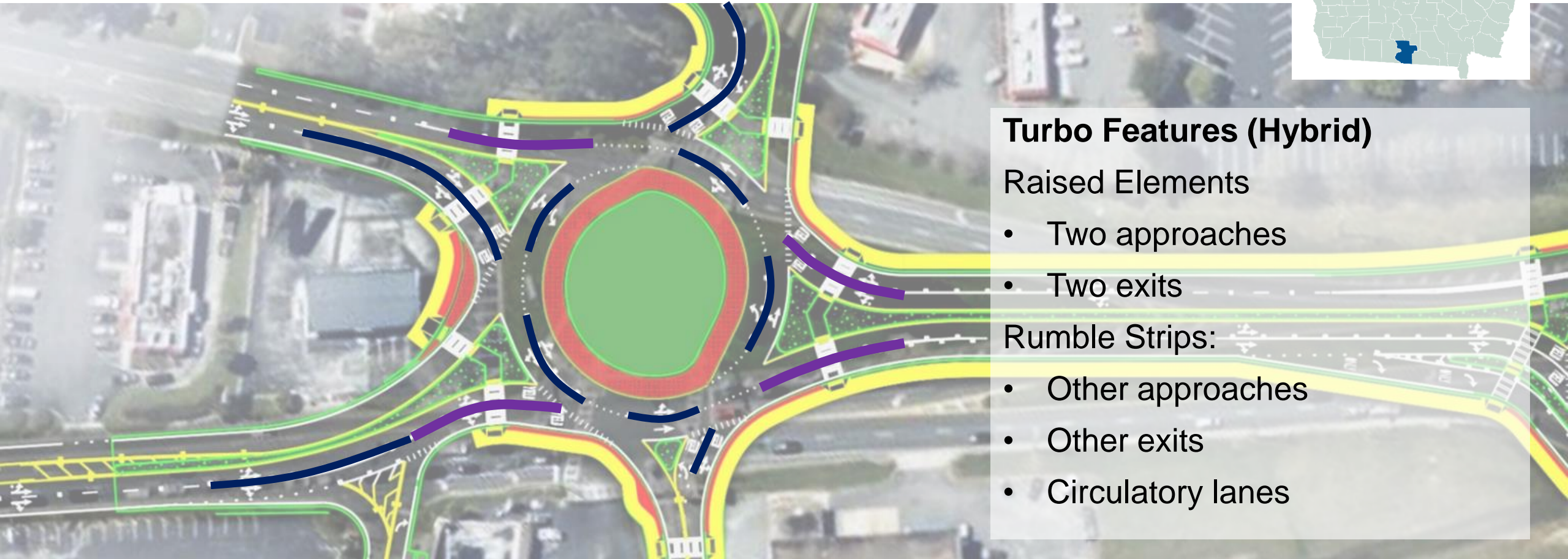

### **Turbo Features (Hybrid)**

#### **Raised Elements**

- Two approaches
- Two exits

#### **Rumble Strips:**

- Other approaches
- Other exits
- Circulatory lanes

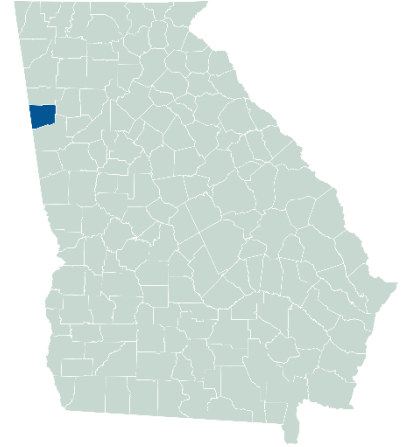

# Case Study 3

## Haralson County

### SR 1 at SR 120

## Case Studies – Haralson County

**SR 1 at SR 120**     **Safety Project, 65 mph**

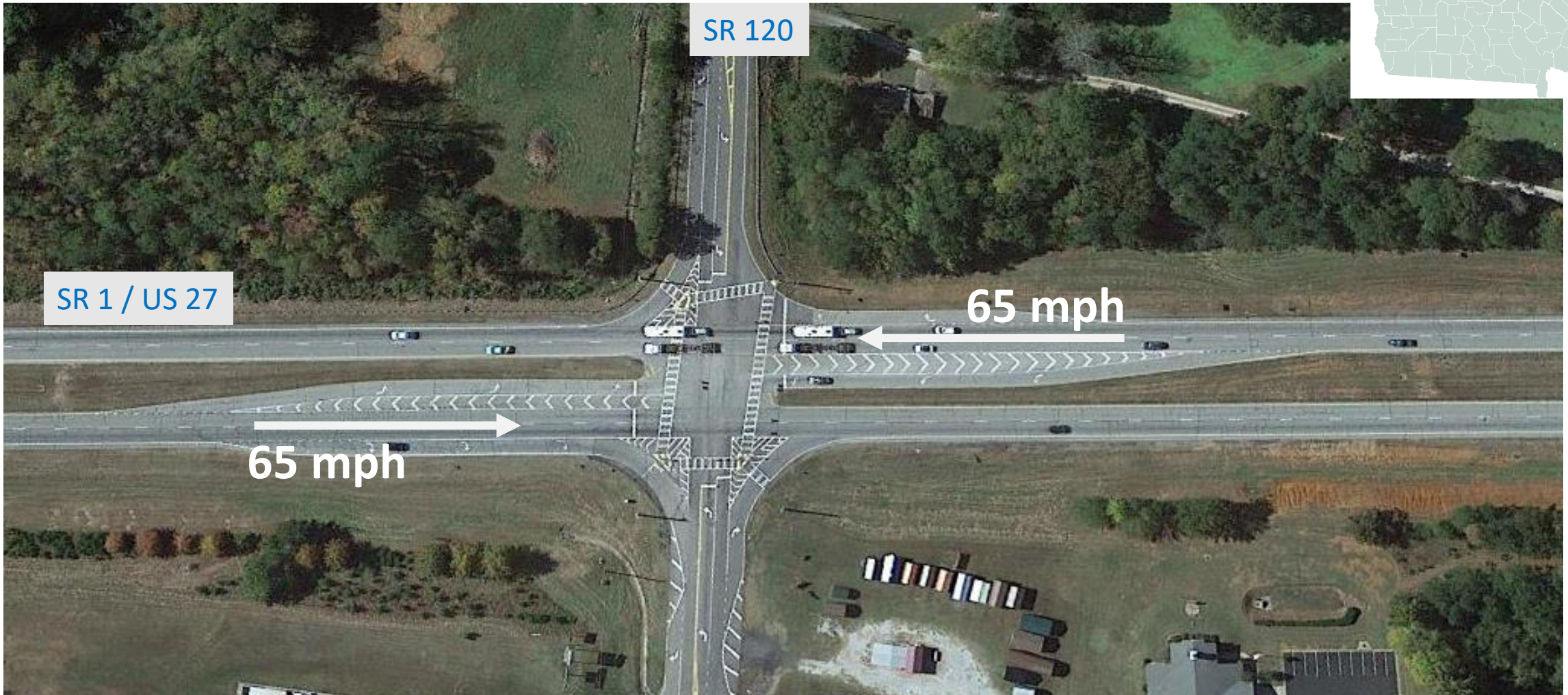
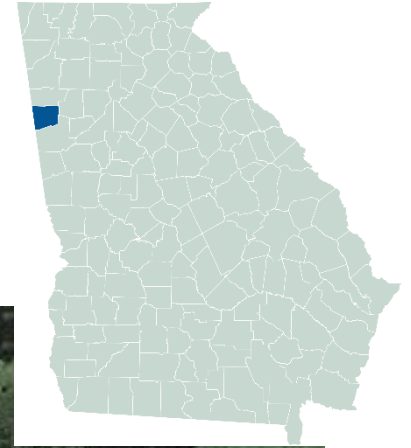

## Case Studies – Haralson County

**SR 1 at SR 120**     **Safety Project, 65 mph**

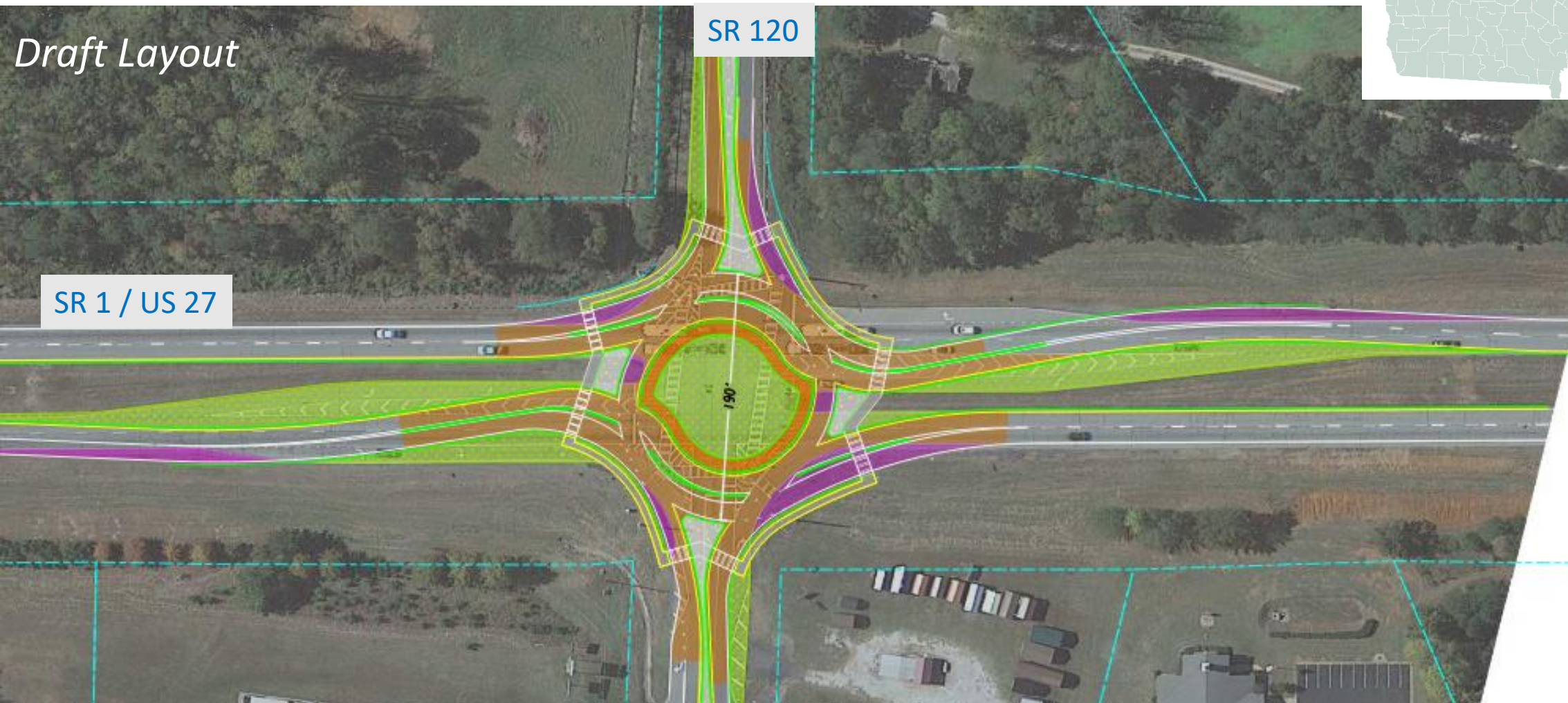
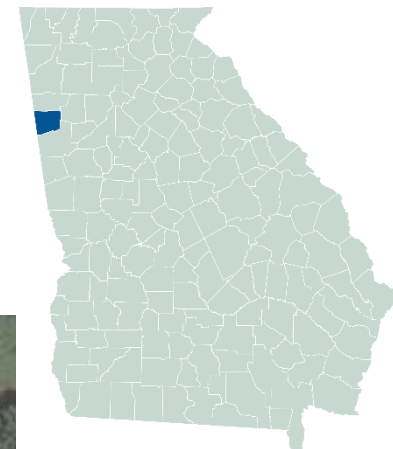

# Case Studies – Haralson County

**SR 1 at SR 120**     **Safety Project, 65 mph**

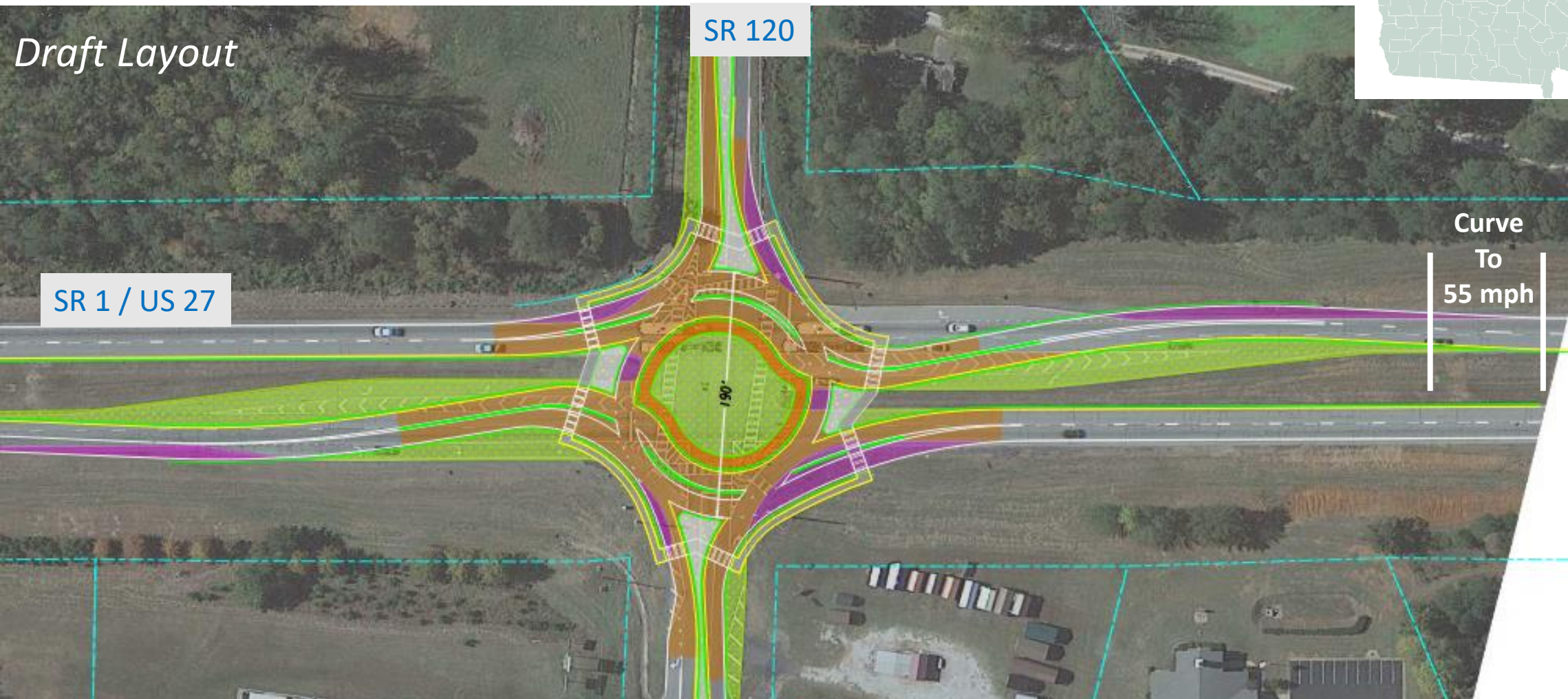
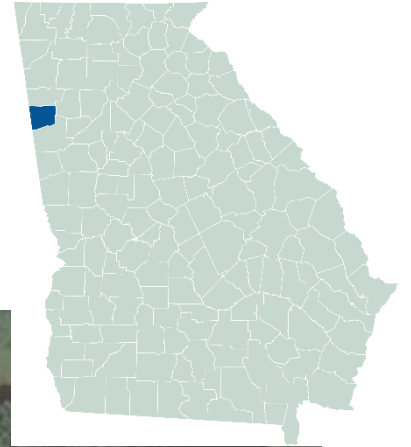

## Case Studies – Haralson County

**SR 1 at SR 120**     **Safety Project, 65 mph**

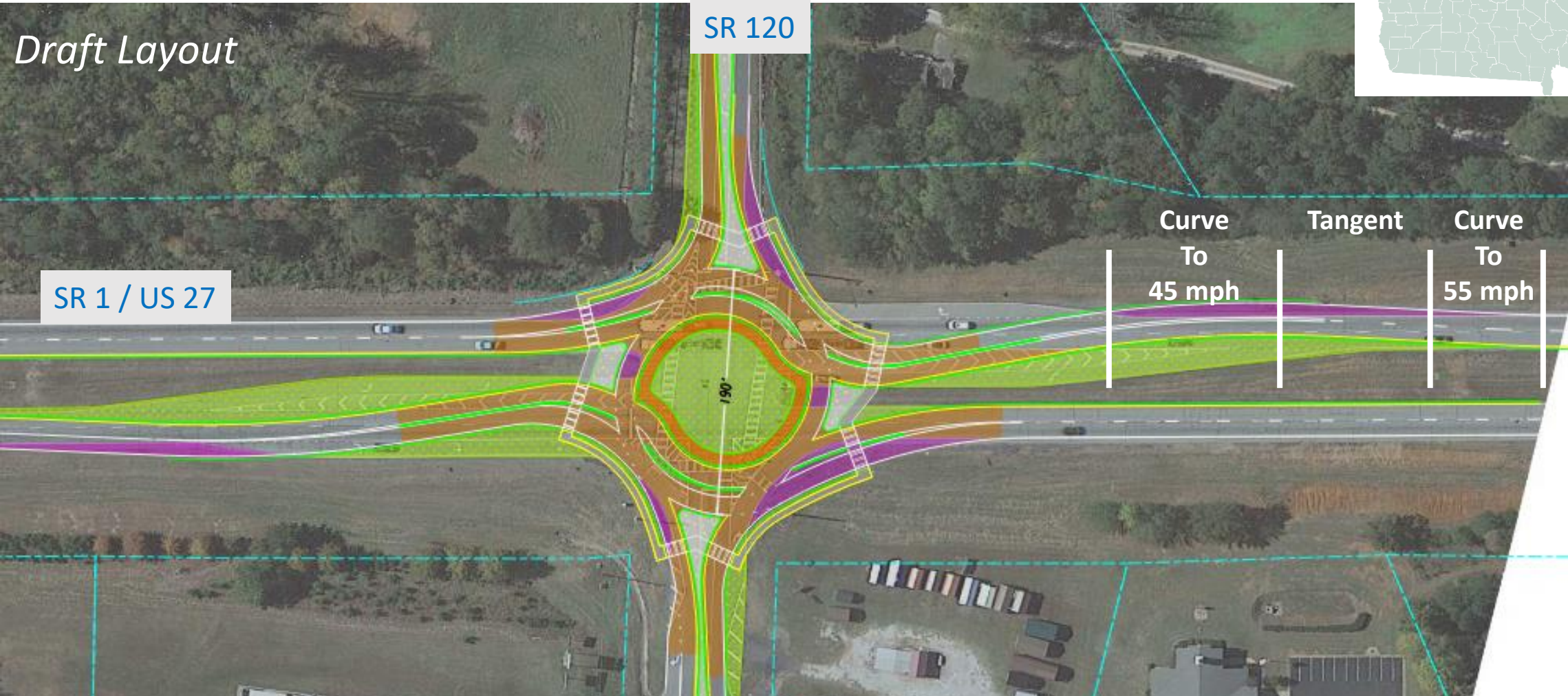
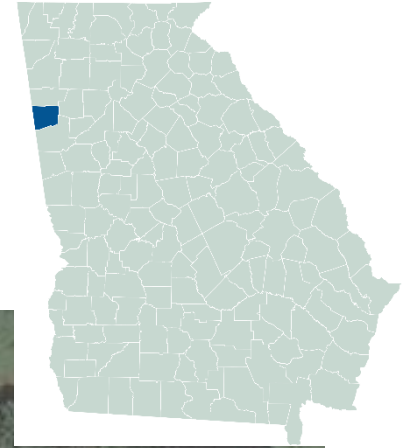

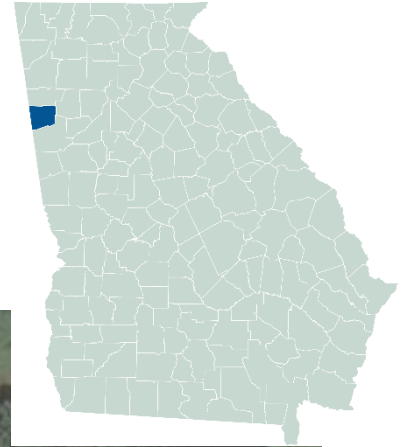

# Case Studies – Haralson County

**SR 1 at SR 120**     **Safety Project, 65 mph**

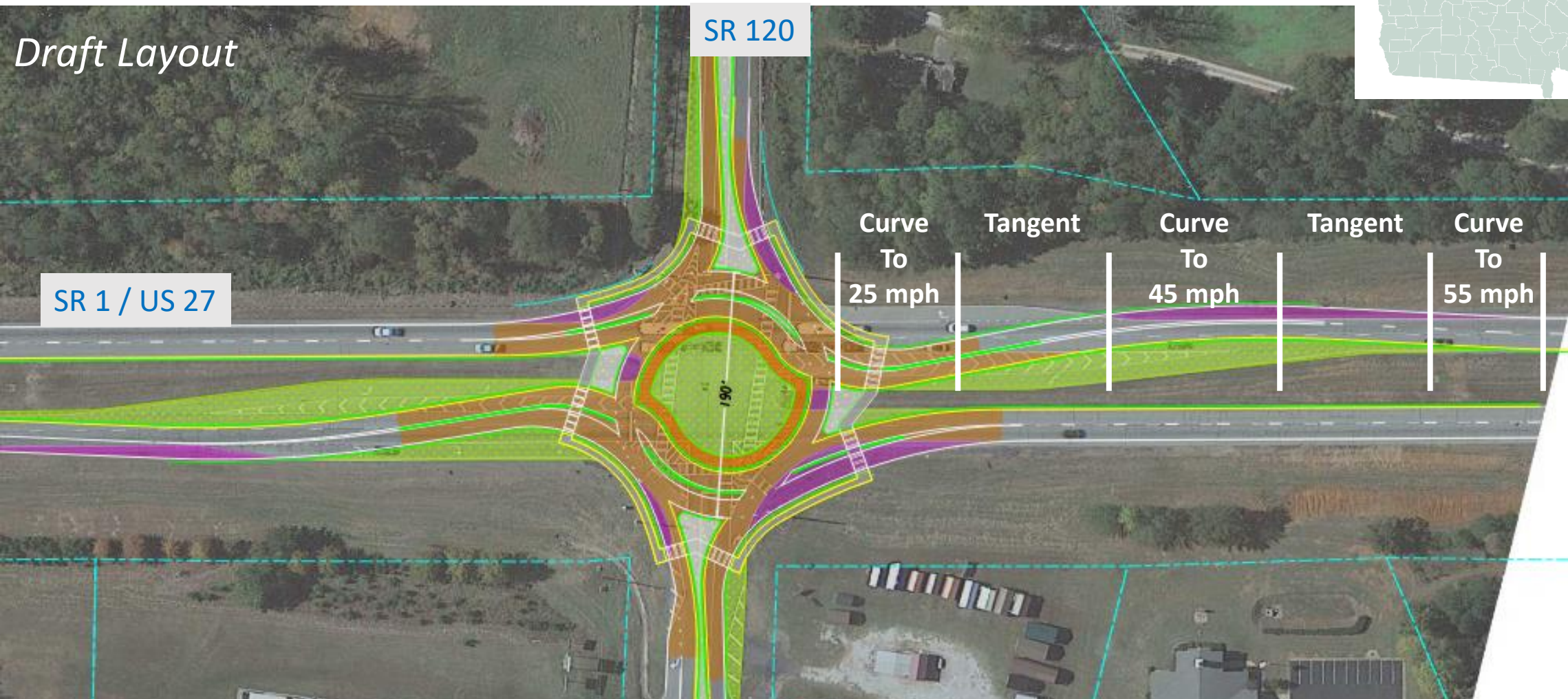

# Case Studies – Haralson County

**SR 1 at SR 120**     **Safety Project, 65 mph**

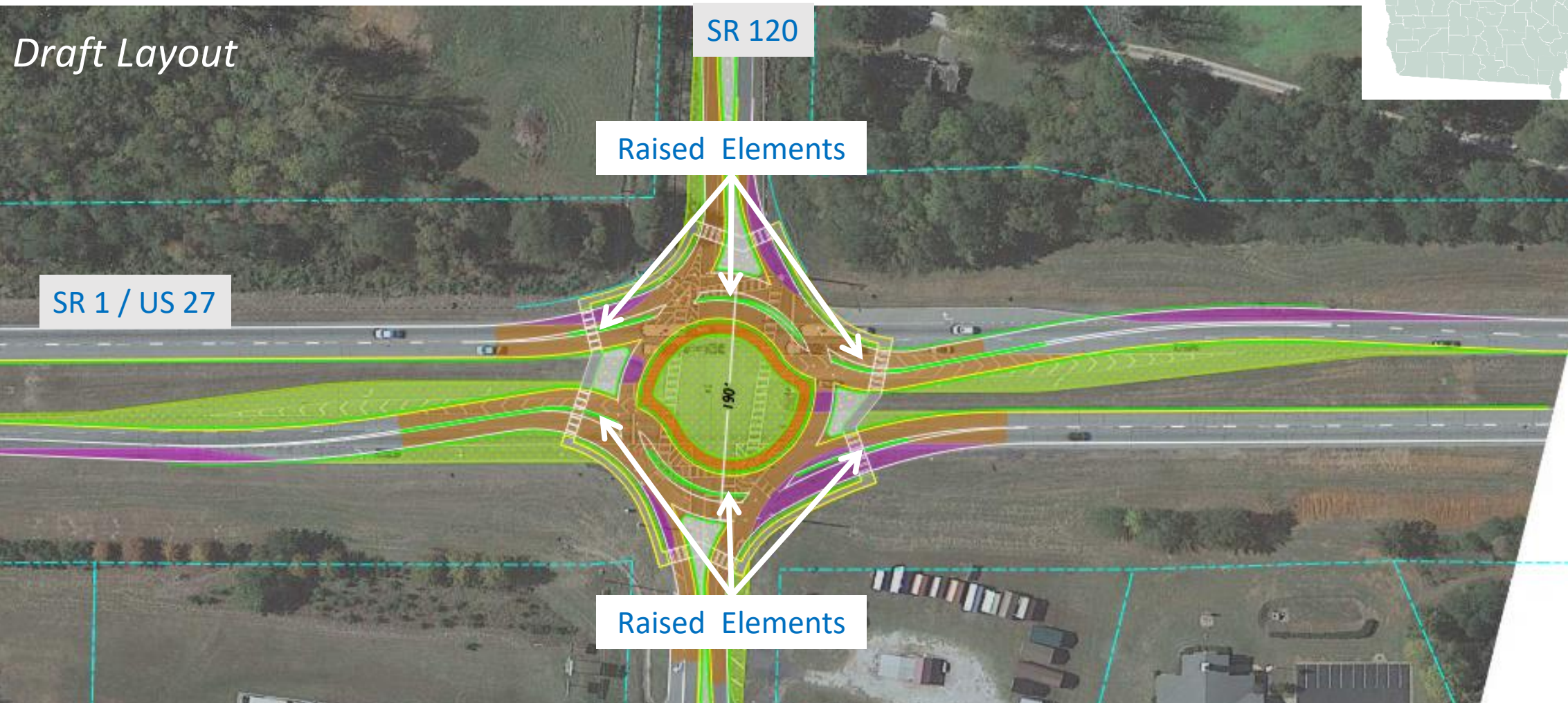
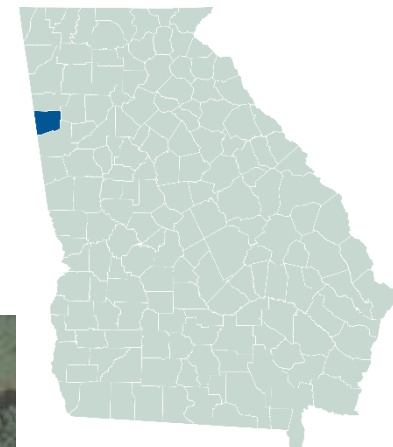

## Case Studies – Haralson County

**SR 1 at SR 120**     **Safety Project, 65 mph**

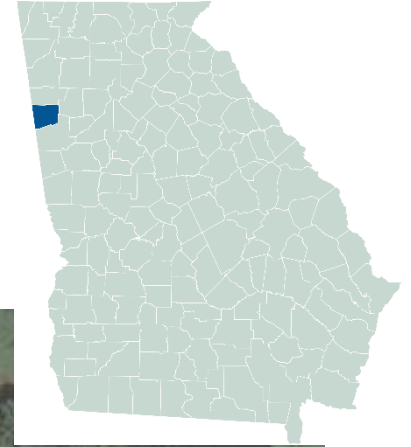

### High speed approaches

- Reduce speeds with chicanes
- Overhead signs upstream (guidance and attention)
- Make it look like you want to slow down
  - Urban look
  - Curb and gutter
  - Lighting
  - Narrower entry lanes
  - Narrower circulatory lane: Raised Elements

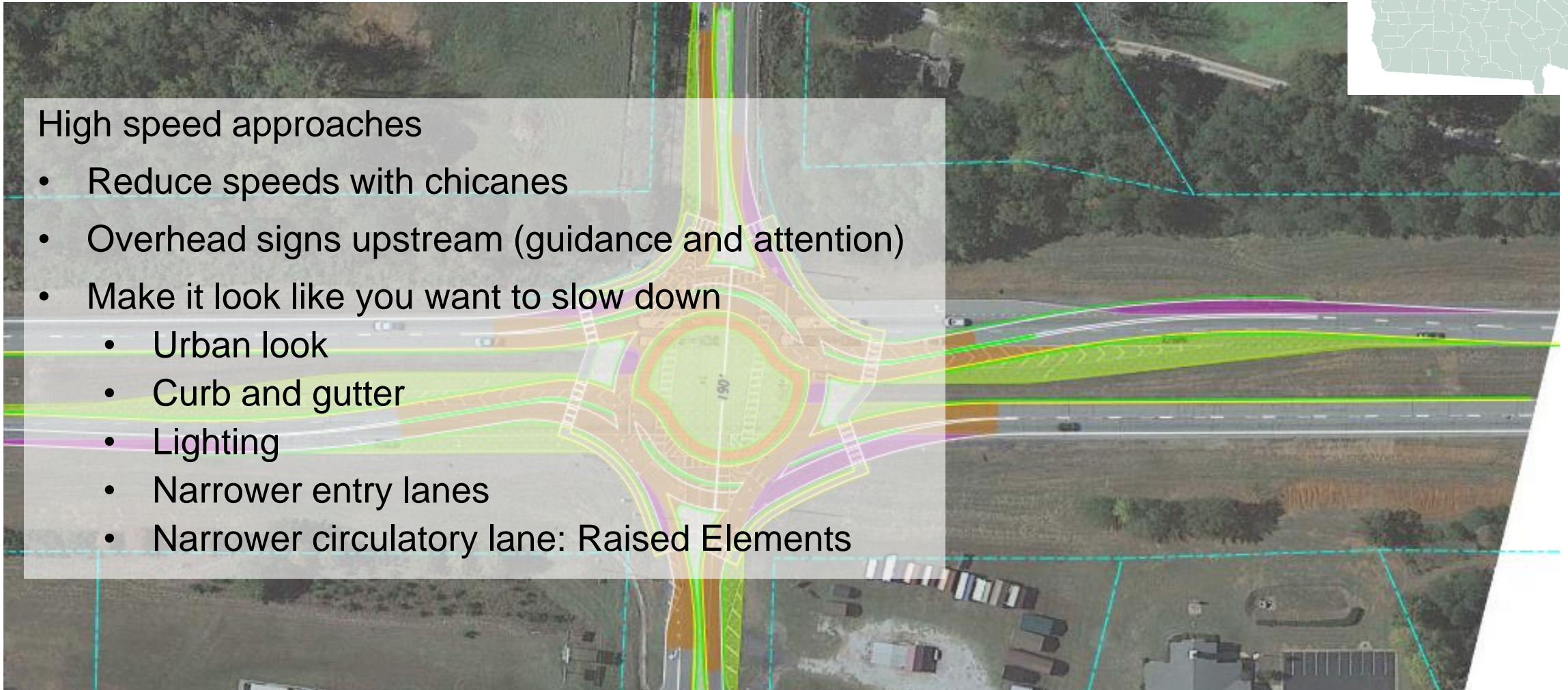

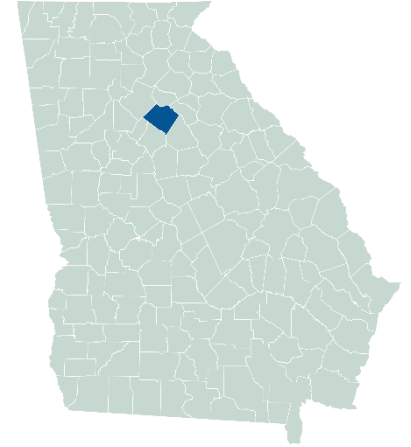

# Case Study 4

## Walton County

### SR 138 at SR 81

# Case Studies – Walton County

## SR 138 @ SR 81

### Roadway Design Project PI 0014802

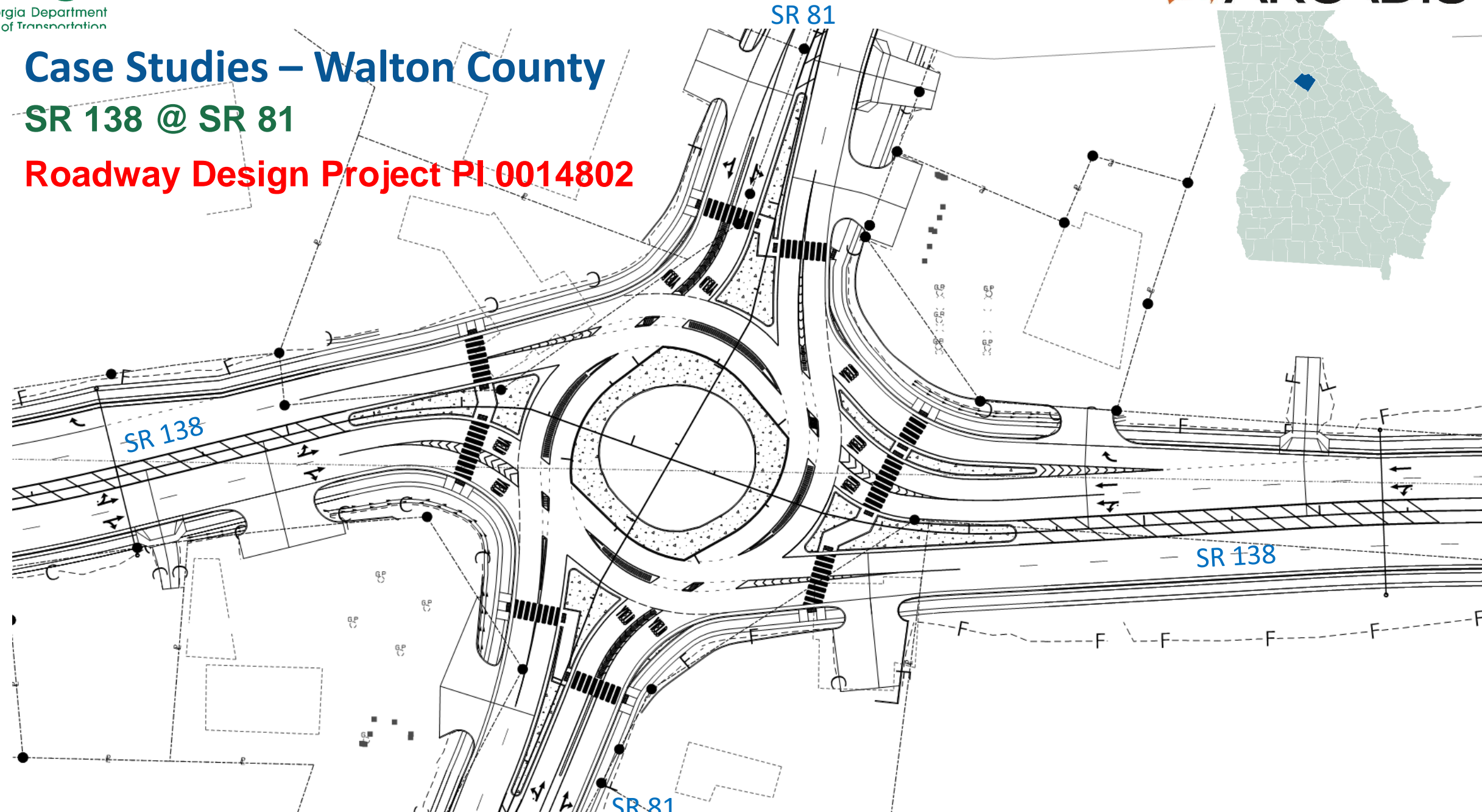
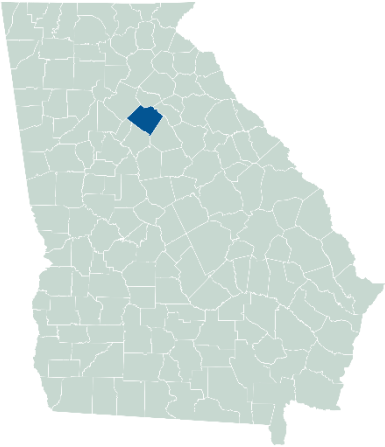

# Case Studies – Walton County

SR 138 @ SR 81

Roadway Design Project PI 0014802

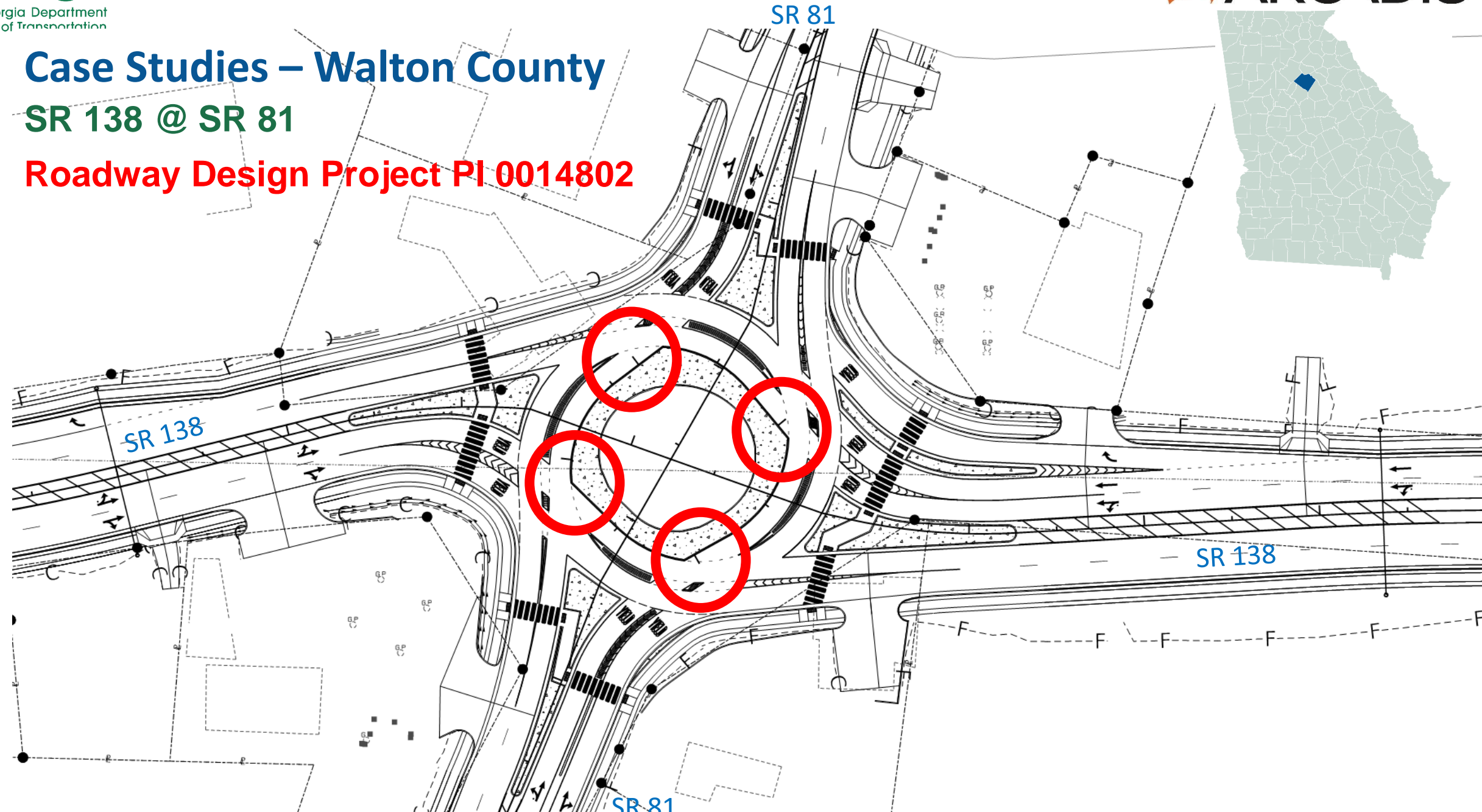
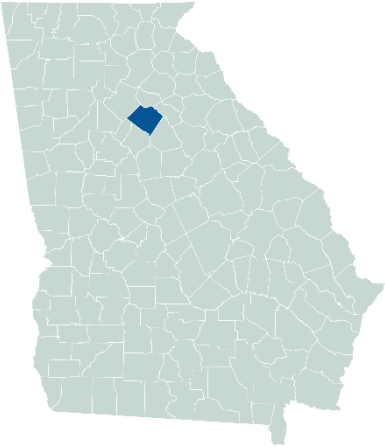

# Case Studies – Walton County

## SR 138 @ SR 81

### Roadway Design Project PI 0014802

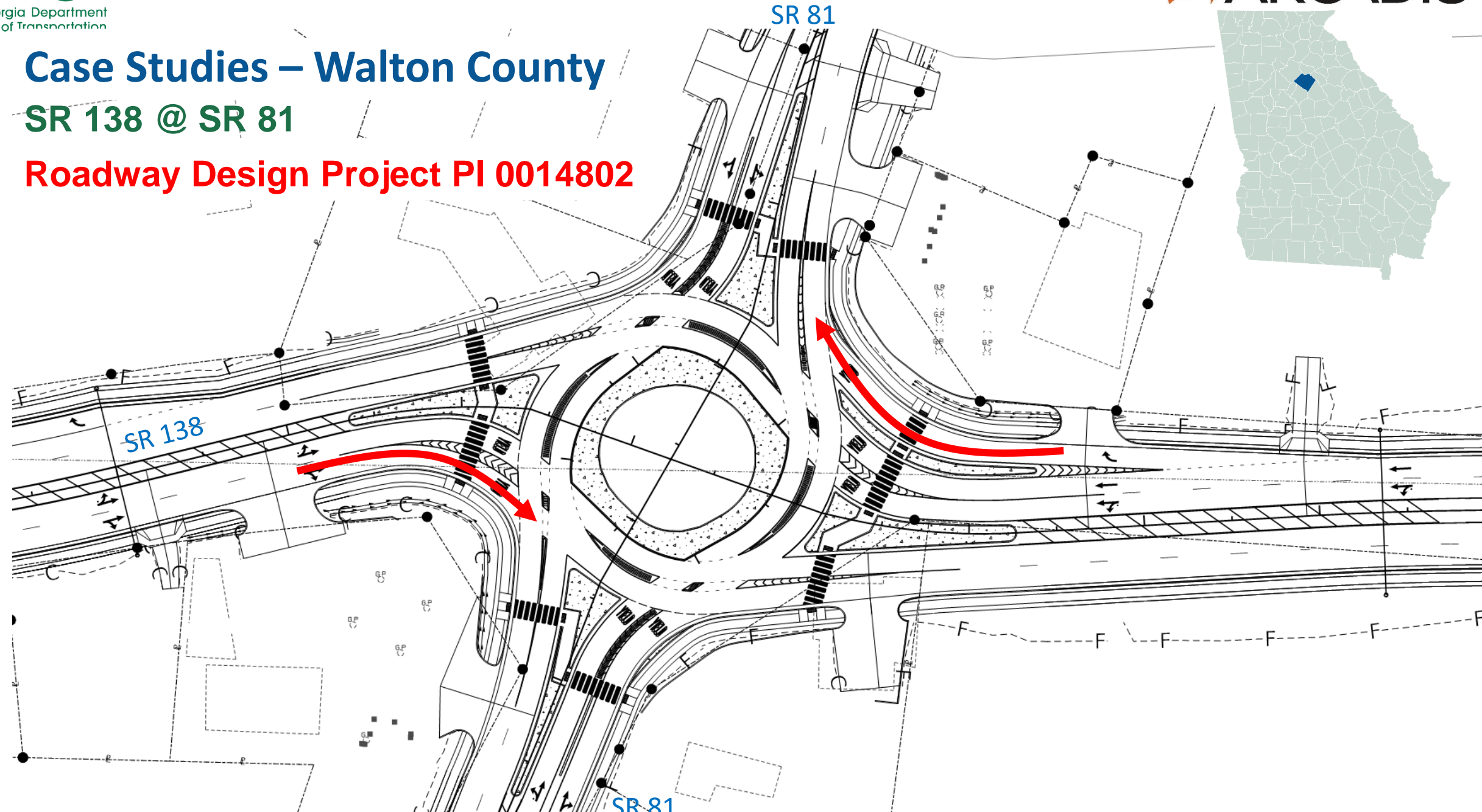
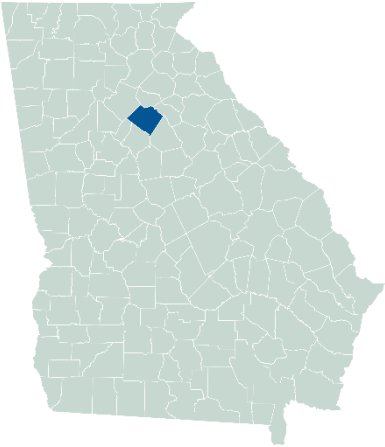



# Case Study 5

## Newton County

### SR 12 at SR 142

# Case Studies – Newton County

## SR 12 @ SR 142 **Operational Project**

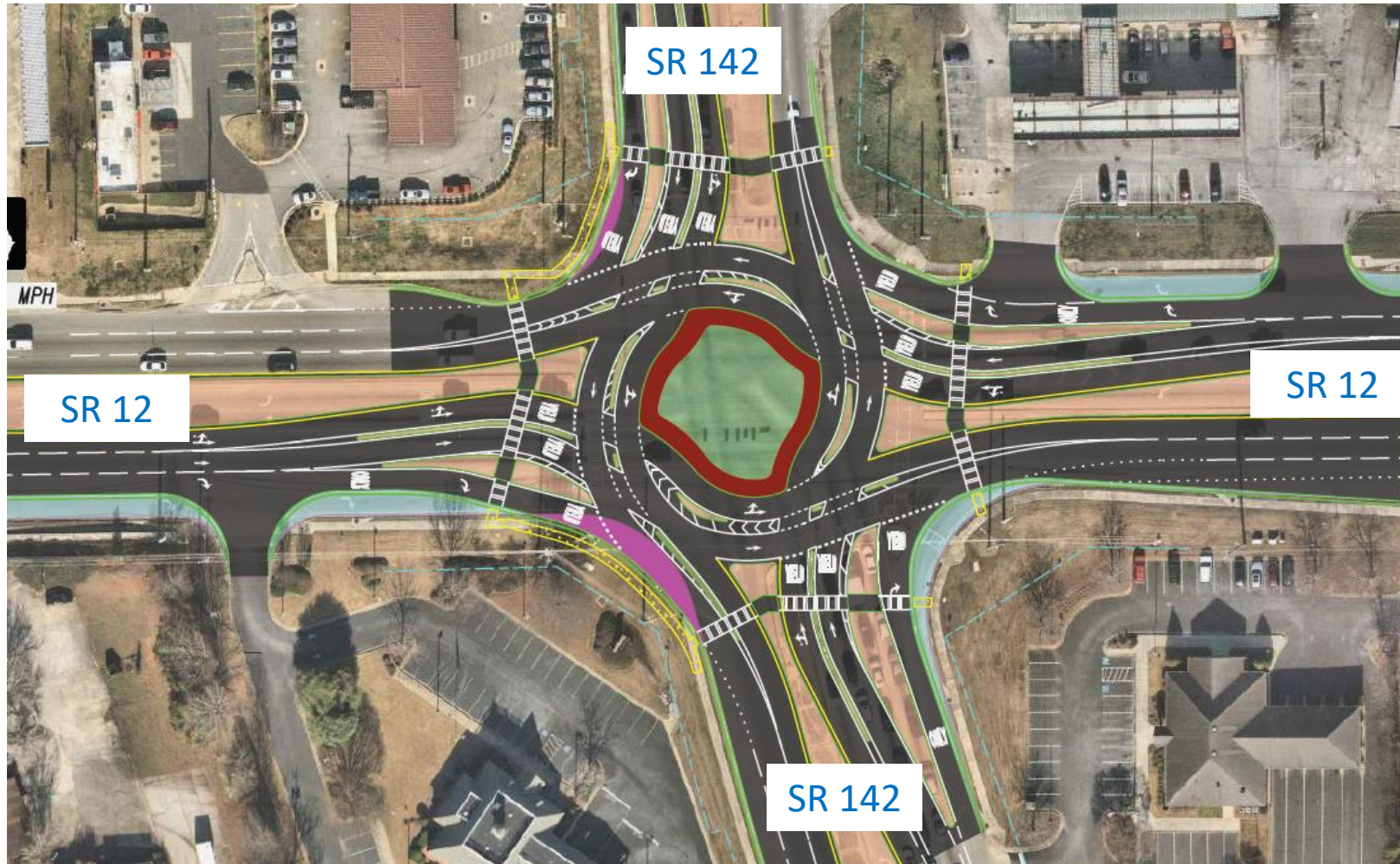

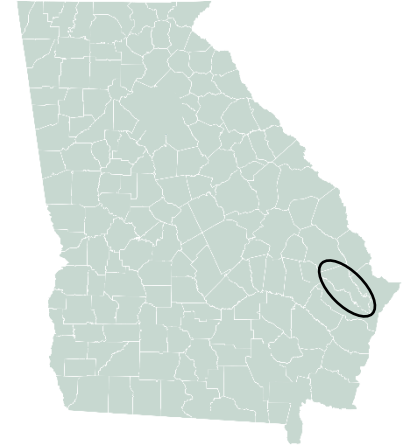

# Case Study 6

## Bryan County

### SR 280

# Case Studies – Bryan County

## SR 280 Design Build

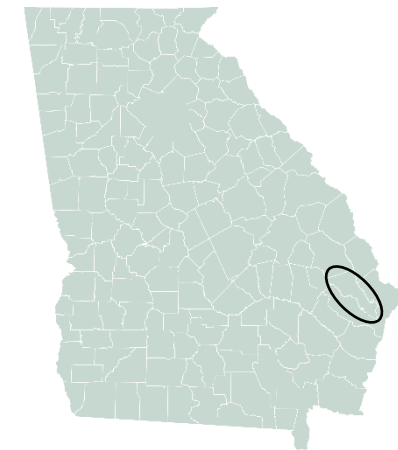

# Case Studies – Bryan County

## SR 280 Design Build

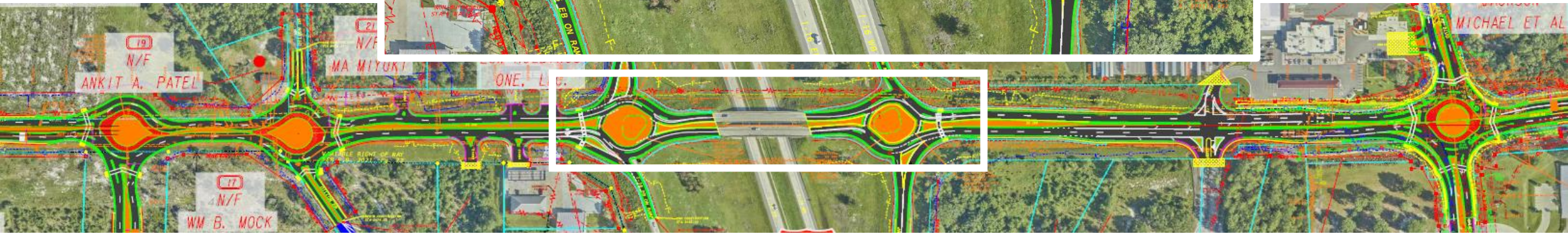
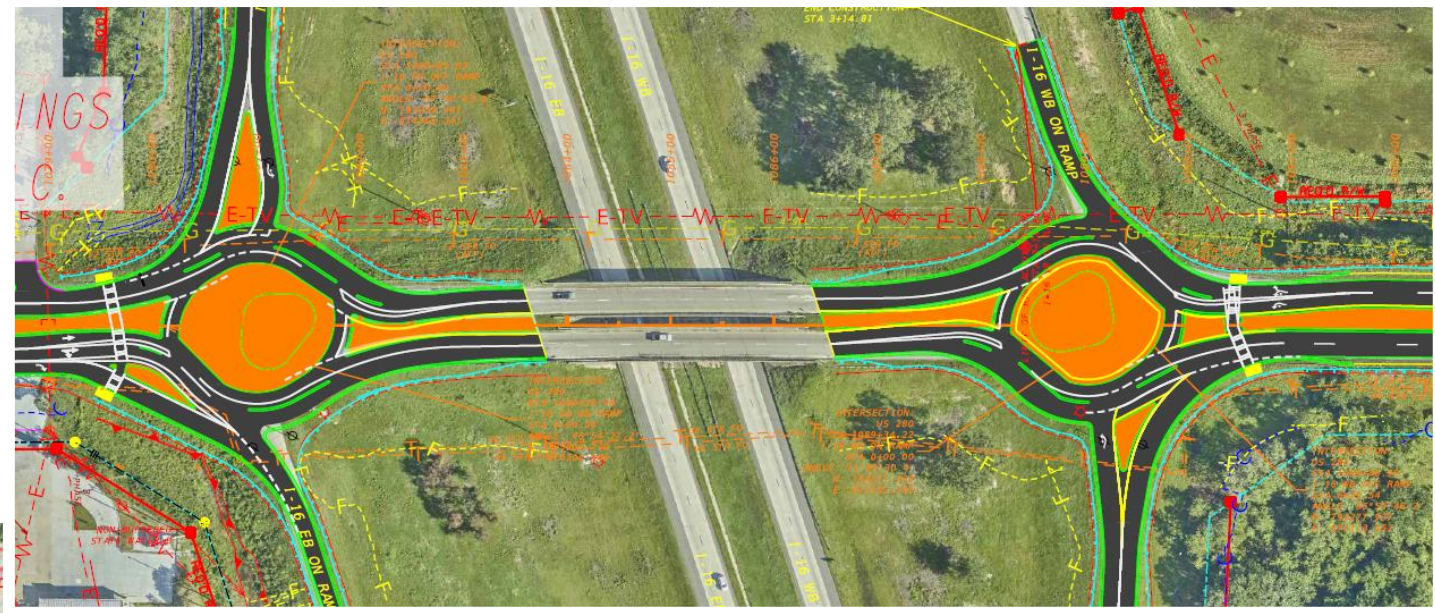
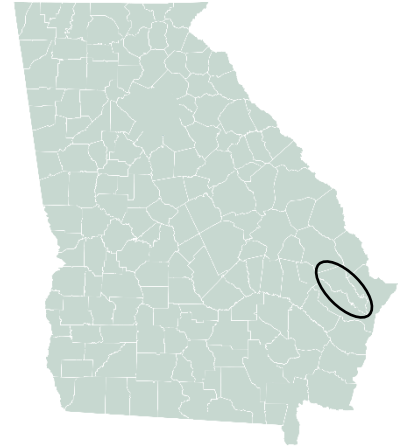

# Case Studies – Bryan County

## SR 280 Design Build

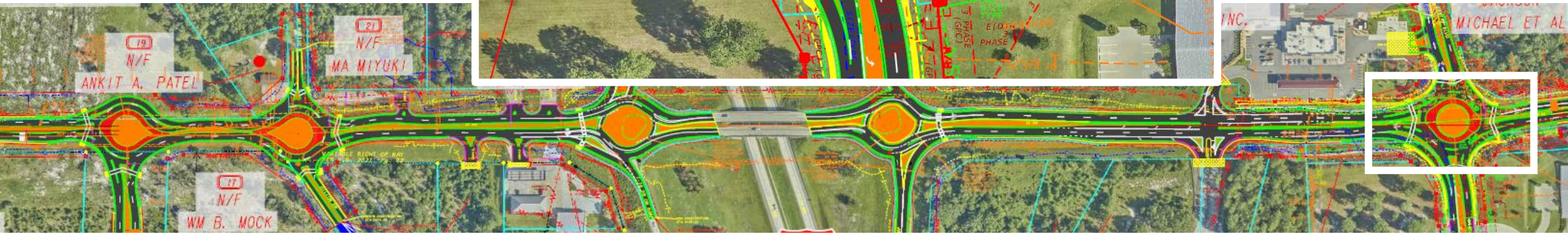
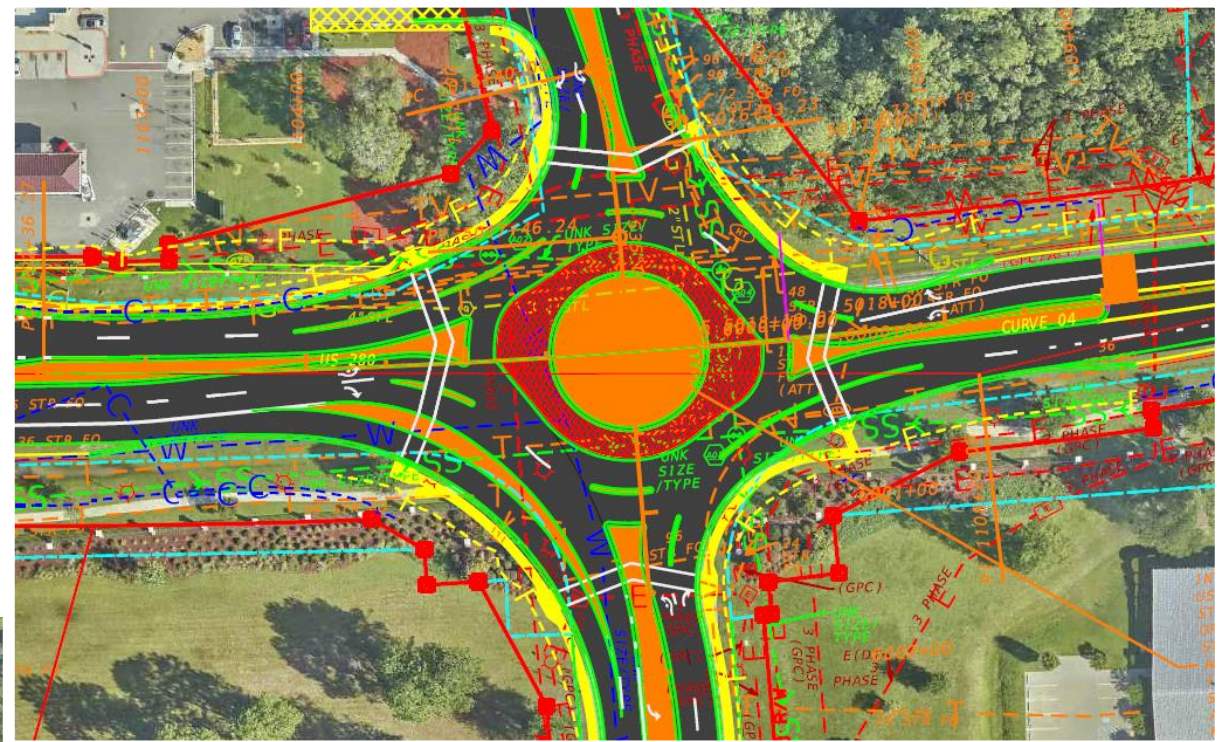
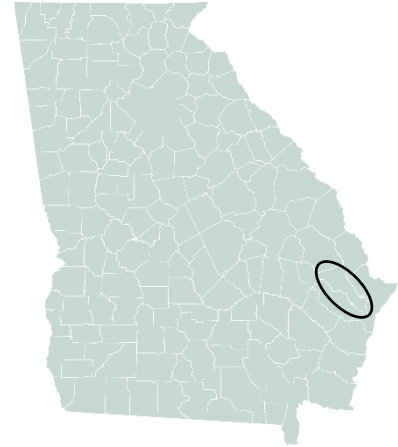

# Case Studies – Bryan County

## SR 280 Design Build

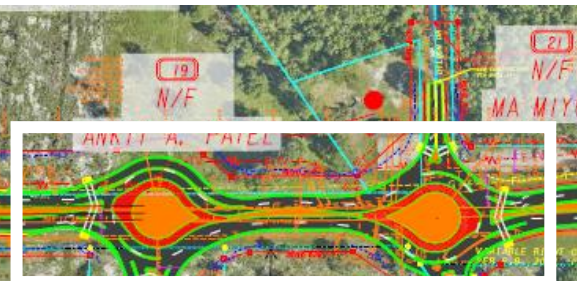
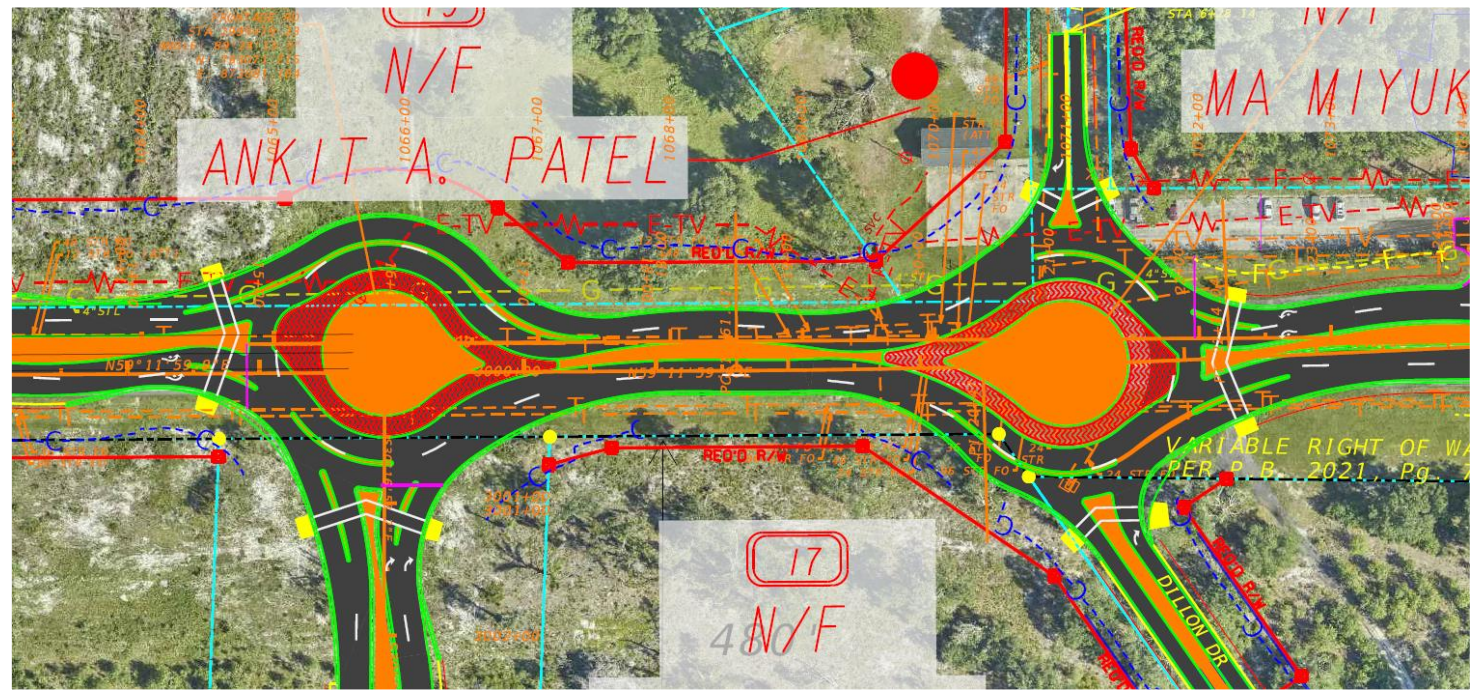
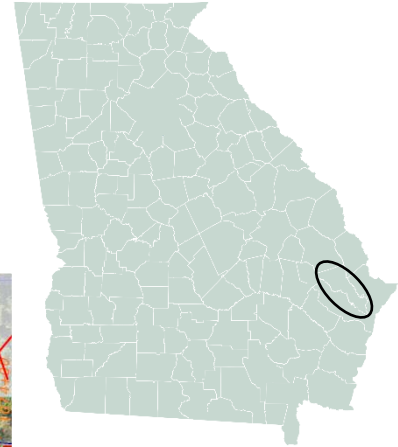

# Final Thoughts as Designer...



Evolution



Evolution



## Final Thoughts

### Multilane Roundabouts:

- Case 3 design is preferred
- Left offset is best
- Entry speeds of 25 MPH or lower is the goal
- Buffer creates offset for better sight distance
- Utilize splitter island for traffic claiming along highspeed approaches & pedestrian accessibility and refuge
- Verify your design vehicles & design checks
- Verify operations and proposed configuration are aligned
- Geometrics, operations, and safety go hand in hand

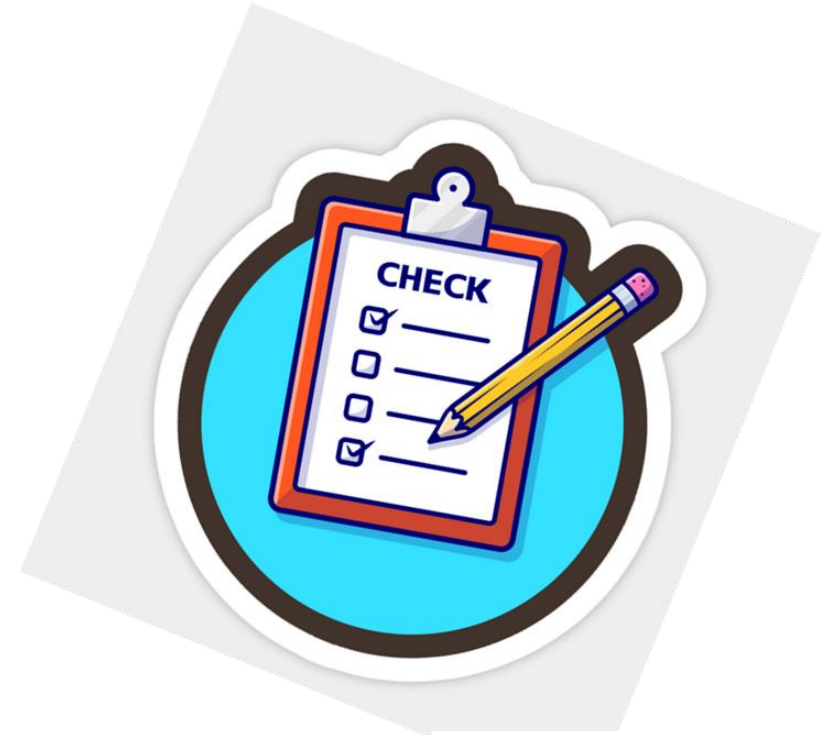

## Questions?

# Oladimeji Onabanjo, PE

State Traffic Operations Manager  
GDOT Office of Traffic Operations  
Office #: 404-635-2830

Email: [oonabanjo@dot.ga.gov](mailto:oonabanjo@dot.ga.gov)

# Jaap Tigelaar

Arcadis

Office #: 770-906-6823

Email: [jaap.Tigelaar@arcadis.com](mailto:jaap.Tigelaar@arcadis.com)

